

WIRELESS SETS No. 18
Mark I, Mark II and Mark III

**WORKING
INSTRUCTIONS**

NOT TO BE PUBLISHED

The information given in this document is not to be communicated, either directly or indirectly, to the Press or to any person not holding an official position in His Majesty's Service.

Z.A. 3207

WIRELESS SETS No. 18
Mark I, Mark II and Mark III

WORKING
INSTRUCTIONS

NOT TO BE PUBLISHED

The information given in this document is not to be communicated, either directly or indirectly, to the Press or to any person not holding an official position in His Majesty's Service.

Z.A. 3207

P/E 154

WIRELESS SETS No. 18
Rapid change from Static to Battle battery.

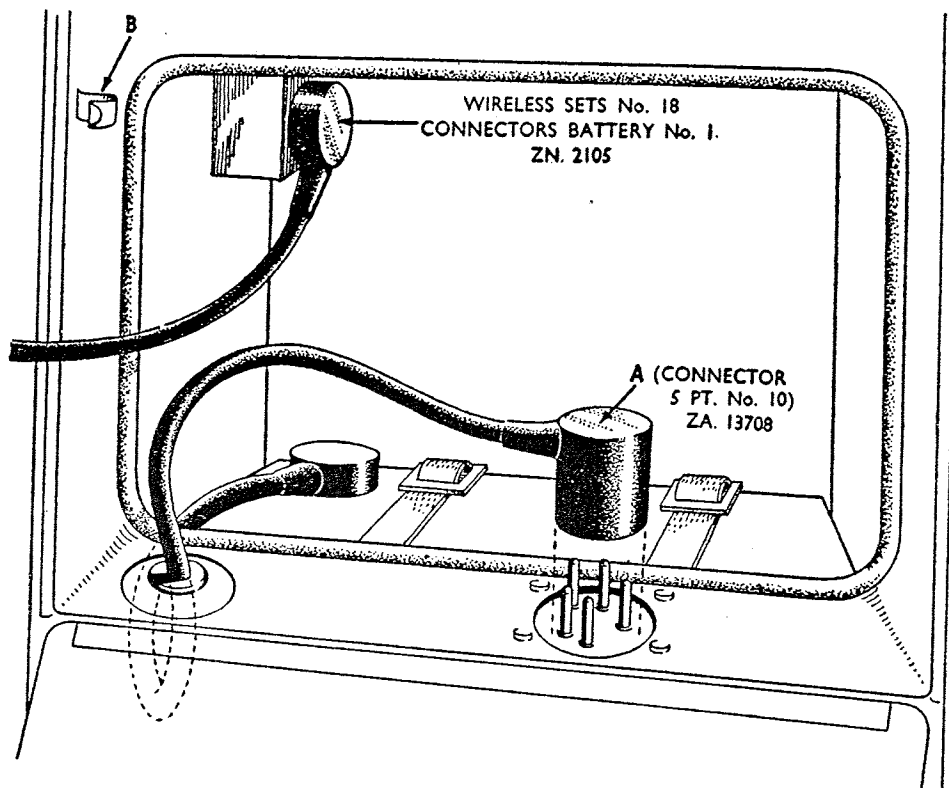

When changing from Static to Battle battery remove Socket "A" and replace by Connectors 5 PT. No. 6 MK I or III. Socket "A" to be clipped under clip "B" when not in use.

CONTENTS

	Page
Prefatory Note—Modifications - - - - -	4
CHAPTER I	
GENERAL DESCRIPTION - - - - -	5
1. Purpose - - - - -	5
2. Frequency range - - - - -	5
3. Aerials - - - - -	5
(a) Ground aerial - - - - -	5
(b) Horizontal half or quarter wave aerials - - - - -	5
4. Sender - - - - -	6
(a) The circuit - - - - -	6
(b) Netting - - - - -	6
(c) Modulation - - - - -	6
(d) Send-receive switch - - - - -	6
(e) C. W. working - - - - -	6
(f) Power supply - - - - -	7
5. Range of working - - - - -	7
TABLE I—Range of Wireless Sets No. 18 - - - - -	7
6. Receiver - - - - -	8
(a) The circuit - - - - -	8
(b) Selectivity - - - - -	8
7. Weights and dimensions - - - - -	8
8. The controls - - - - -	8
(a) The sender - - - - -	8
(b) The receiver - - - - -	9
9. Constructional details - - - - -	9
CHAPTER II	
WORKING INSTRUCTIONS - - - - -	10
1. Preliminary - - - - -	10
2. Tuning the sender - - - - -	11

	Page
3. Tuning the receiver - - - - -	11
4. The netting procedure - - - - -	12
5. Send-receive switching - - - - -	13
6. Mobile working - - - - -	14
7. Operation of mobile sets in the open under fire - - - - -	14
8. Choice of a site for stationary working - - - - -	14

CHAPTER III

AERIALS FOR USE UNDER VARIOUS CONDITIONS -	15
1. The rod aerial and ground aerial - - - - -	15
2. Choice of aerial - - - - -	15
3. Aerials suitable for use with Wireless Sets No. 18 in open positions - - - - -	15
4. Aerials suitable for use with Wireless Sets No. 18 under cover - - - - -	16
5. Aerials for long range use - - - - -	16
6. Tuning the power amplifier and aerial circuits of the sender when the Wireless Sets No. 18 is used with a Wyndom or end-fed horizontal aerial - - - - -	16
7. The use of an earth - - - - -	17

CHAPTER IV

MAINTENANCE - - - - -	18
1. General maintenance - - - - -	18
(a) The rod aerial - - - - -	18
(b) The ground aerial - - - - -	18
(c) The control panel - - - - -	18
(d) The battery compartments - - - - -	18
(e) The plugs sockets and leads - - - - -	18
2. Sender and receiver test figures - - - - -	19
(a) The test meter and "METER SWITCH" - - - - -	19
TABLE II—Wireless Sets No. 18—Test Meter Readings	19
(b) Other test points on the receiver and sender -	19
TABLE III—Voltage and Current Analysis of Sender and Receiver and Point to Point Check - - -	20 & 21

	Page
TABLE IV—P.2.A. Point to Point Check - -	20 & 21
TABLE V—Mic P.1.A. Point to Point Check -	20 & 21
(c) Receiver sensitivity tests - - - -	22
3. Fault location - - - - -	22
(a) Sender faults - - - - -	23
TABLE VI—Sender Faults - - - - -	23
(b) Receiver faults - - - - -	26
TABLE VII—Receiver Faults - - - - -	27
TABLE IX—Wireless Sets No. 18 Mark I & II—	
Components - - - - -	29
Wireless Sets No. 18 Mark III—Components -	32

APPENDIX

CIRCUIT AND LAYOUT DIAGRAMS - - - -	35
-------------------------------------	----

Wireless Set No. 18 Mark III.

- Fig. 1 Front view of receiver panel.
- Fig. 2 Front view of sender panel.
- Fig. 3 Top view of receiver chassis.
- Fig. 4 Underside view of receiver chassis.
- Fig. 5 Top view of sender chassis.
- Fig. 6. Underside view of sender chassis.
- Fig. 13 Sender circuit diagram.
- Fig. 14 Receiver circuit diagram.

Wireless Set No. 18 Mark II.

- Fig. 7 Front view of receiver panel.
- Fig. 8. Front view of sender panel.
- Fig. 9 Top view of receiver chassis.
- Fig. 10. Underside view of receiver chassis
- Fig. 11 Top view of sender chassis.
- Fig. 12 Underside view of sender chassis.
- Fig. 15 Sender circuit diagram.
- Fig. 16 Receiver circuit diagram.

Wireless Set No. 18 Mark I.

- Fig. 17. Receiver circuit diagram.

WIRELESS SETS NO. 18

SERIAL NUMBERS.

Description	Serial Nos.
Wireless Sets No. 18 Mark I	0001-0250
Wireless Sets No. 18 Mark I	0251-1000
Wireless Sets No. 18 Mark II	1001-2000
Wireless Set No. 18 Mark III	2001-

NOTES.

Wireless Sets No. 18 Mark I are not equipped for C.W. operation.

Wireless Sets No. 18 Serial Nos. 0001-0250 are not fitted with the battery switch S.4.B, and the following components are omitted or modified.

S.4.B; R.20.A

R.8.A is 3 ohms; R.9.A is 8 ohms

R.8.B is 6 ohms; R.13.A is 0.9 ohms.

Wireless Sets No. 18 Mark III are fitted with filament resistances R21A-B (marked "S" and "R" respectively), and Sensitivity switch S.4C on Receiver.

Retrospective Action has been taken to modify Wireless Sets No. 18 Mark I and Mark II for use with the Microphone Hand No. 4A (Resistance R.20.A was 0.75 ohm).

CHAPTER I

GENERAL DESCRIPTION

1. Purpose.

The Wireless Set No. 18 is designed for short range telephony and C.W. working in forward areas, and is primarily intended for use between Battalion H.Q. and Company H.Q. It may be used as a ground station for working in the open or from cover, and as a man-carried pack set for working on the march.

The set is entirely self-contained in one unit containing Sender, Receiver and Batteries.

2. Frequency range.

The set covers a frequency band of 6 mc/s-9 mc/s (50 metres-33.3 metres) in a single range. This band normally provides a minimum of about eighteen channels of communication outside the Army band, i.e. above 7500 kc/s, and also gives an adequate overlap into the Army band to permit working with Wireless Sets No. I and Wireless Sets No. II.

3. Aerials.

A sectional rod aerial is packed with the set and may be erected on the set to give a self-supporting aerial up to 10 feet high.

Other forms of aerial which may be used with the set are given below. Their uses are described in detail in Chapter III.

(a) *Ground aerial.*

The ground aerial consists of a length of insulated wire connected to the aerial circuit of the set at one end and thrown out along the ground. It is intended for working from trenches and other forms of cover where a vertical rod aerial would be too conspicuous. In certain circumstances the ground aerial may be used as an elevated extension to the rod aerial.

(b) *Horizontal half or quarter wave aerials.*

For long range working half or quarter wave horizontal aerials may be used. They may be either end-fed half or quarter wave aerials or "Wyndom" aerials. For working into the Army band, i.e. below 7.5 mc/s, an Aerial Horizontal End-fed or an Aerial Horizontal C, as used with Wireless Sets No. II, may be used.

4. Sender.

(a) *The circuit.*

The signal frequency of the sender is generated by a master oscillator circuit followed by a single power amplifier. The aerial is auto-coupled to the power amplifier by aerial taps to a parallel tuned output circuit.

There are thus three tuning controls, the "M.O. TUNING," "AERIAL TUNING" and "AE SWITCH."

(b) *Netting.*

By means of the netting device a group of Wireless Sets No. 18 may be tuned to one frequency simultaneously, the frequency chosen being radiated in the first instance as a signal by a central control station. Any set may then communicate with any other set in the group or with the control station. Such a group is termed a "net" and the process of tuning the sets in the net to a common frequency, "netting."

The netting device used in the Wireless Set No. 18 consists of a plunger switch by which the master oscillator valve of the sender may be switched on while the set is in the receiving condition. When netting, the master oscillator frequency is adjusted so that a beat note is heard between the master oscillator and the incoming signal. When the beat note is set to zero, the frequency of the master oscillator is the same as that of the incoming signal.

(c) *Modulation.*

Modulation takes place on the control grid of the power amplifier valve and is set to give full modulation of the carrier at a normal loud voice level. No adjustment for depth of modulation is provided.

(d) *Send-receive switch.*

Changing over from send to receive is performed by the pressel switch of the microphone. There is no change-over switch on the panel of the set.

(e) *C.W. working. Mark II and III.*

For the purpose of C.W. transmission a close-circuit jack is connected in the H.T. supply to the P.A. valve, and a Key is connected by means of Key and Plug Assembly No. 8 for C.W. operation. The above Key embodies the send-receive switch which is connected to the filament supplies of sender and receiver.

(f) *Power supply.*

The power supply for the set is derived from dry (primary) batteries. The filament heating for both sender and receiver is provided by a 3-volt battery through suitable voltage dropping resistances and a 162 volt battery tapped at 12 volts provides H.T. and Grid Bias. All these batteries are housed in a single pack.

The L.T. consumption is 0.35A on send and 0.2A on receive. The H.T. consumption is 18-20mA on send and 15mA on receive.

Assuming a ratio of transmission to reception time of 1 to 3 about 8-12 hours continuous operation of the set is possible without changing the batteries. For more intermittent working the useful life of the batteries is greatly increased.

For permanent station use Wireless Set No. 18 should be connected by a Lead Connector 5 point No. 6 to a Boxes Primary Battery H.T. + L.T. -162/3 No. 1.

5. *Range of working.*

The range of the Wireless Set No. 18 depends on the type of aerial used and the nature of the surrounding country. For information, the following table indicates approximate ranges which may be expected between two sets using the same type of aerial, over average country in England.

TABLE I
RANGE OF WIRELESS SETS NO. 18

Aerial	Range
10 ft. rod	Over 5 miles
6 ft. rod	2-5 miles
Ground Aerial	1-3 miles*

* The range given is that obtainable with the ground aerial operating under the most favourable conditions. Generally, greater range is obtained with the ground aerial when the set is raised off the ground.

Considerably greater ranges are possible if half-wave horizontal aerials are used. These may be either of the single feeder, matched impedance type (commonly referred to as the Wyndom aerial) or of the end-fed half-wave type.

The ranges given above are for telephony and for C.W. working, the range in each case will be about doubled.

6. Receiver.

(a) *The circuit.*

The receiver employs a 4-valve supersonic heterodyne circuit comprising a signal frequency amplifier, frequency changer, intermediate frequency amplifier and 2nd det.-A.V.C.-A.F. stage. The A.F. stage serves also as local oscillator for C.W. reception.

Two types of valves are used, type A.R.8 (1) and A.R.P.12 (3).

(b) *Selectivity.*

The resonance curve of the intermediate frequency amplifier has a width of 7 kc/s with an average cut-off of 5 db/kc/s.

7. Weights and dimensions.

Weight of set in case, with batteries	29 lbs.
Weight of satchel signal containing 2 pairs receiver, headgear, 1 microphone, 1 ground aerial key and plug assembly	5 lbs.
Complete Equipment	34 lbs.

Approximate overall dimensions of set:—
8 ins. × 10 ins. × 17 ins.

8. The controls.

(a) *The sender.*

- (i) The "BATTERIES" switch breaks the H.T., L.T. and G.B. circuits to both sender and receiver.
- (ii) The "M.O. TUNING" dial controls the tuning of the master oscillator circuit and is the main control for the setting of the emitted frequency.
- (iii) The "AERIAL TUNING" dial tunes the output circuit of the power amplifier and the aerial circuit in conjunction with,
- (iv) the "AE SWITCH" which provides tapping points on the tuned circuits inductance of the power amplifier valve.
- (v) The "METER SWITCH" in conjunction with the test meter provides a rapid check for the H.T. and L.T. battery voltages, and the total emission current of the valves in the sender and the receiver.

With the switch in its normal position (marked "AE CURRENT") the meter indicates aerial current.

- | | |
|--|-------------|
| (vi) Rheostat R. controlling fil. volts to Receiver. | } Mark III. |
| (vii) S. " " " Sender. | |

(b) *The receiver.*

- (i) The "REC'R TUNING" is the major control of the receiver, tuning the ganged circuits of the signal frequency and local oscillator stages.
- (ii) The "L.F. GAIN" control limits the input to the triode section of the valve V_4 , and controls the local oscillation* for C.W. reception. Mark II and III.
- (iii) Switch S—Sensitivity Switch to reduce H.T. consumption on strong signals. (Mark III only.)

* Turning this control back through a few degrees from its maximum stops the oscillation. The set should always be used in the non-oscillating condition for reception of telephony.

9. Constructional details.

The Wireless Set No. 18 is housed in a pressed steel case embodying a rucksack frame.

The front of the case is closed by hinged metal flaps and canvas hood. This hood, which is opened when operating the controls of the set, gives good protection against bad weather conditions. The canvas is easily detached for decontamination.

The sender slides into the lower section of the case and the receiver into the upper. Both are held in position by securing screws and may be readily withdrawn for inspection.

The rod aerial consists of sections of $\frac{1}{4}$ -in. copper-plated steel tube one foot long. Twelve are carried in a rack at the side of the set. The rod aerial is mounted on a rotatable moulded plug at the side of the case which allows it to take up a vertical or horizontal position.

The aerial sections are spigoted and may be firmly joined together to form an aerial of up to 10 ft. in height.

Connection between battery and sender unit and between sender and receiver units is by cables terminating in suitable plugs.

IMPORTANT:—If either Marks I, II or III sets are used with external battery and connector 5 pt. No. 6, it must be ensured when connecting up that "SET" end of lead is coupled first. Failure to observe this procedure may result in valves being destroyed.

CHAPTER II

WORKING INSTRUCTIONS

Note.—Before carrying the set see that the securing screws are properly fastened and that the covering flaps are well secured by the retaining straps.

I. Preliminary.

- (a) Stand the set on a table or on the flattest ground available, seeing that it is firm and does not rock.
- (b) Undo the retaining straps and open the flaps.
- (c) The set is normally sent out complete with batteries and valves and ready for operation. If, however, the battery pack is not fitted unscrew the lower fixing screw on back of case and withdraw the sender, after removing the inter-unit connector plug. Pull out the ends of the battery straps to their full extent so that the buckles lie in the recesses at the back of the case. Hold the battery so that the outlet socket is on the under side at the left-hand end, and insert through the sender opening with a rolling motion so that the socket appears on top at the left-hand end. Secure straps. Insert battery plug in socket—the lead points to the front of the case when the plug is in position. Replace sender and inter-unit connector plug and fasten securing screw tightly.
- (d) (Mark I and II). See that the batteries are in good order by checking them on the test meter. Put the "BATTERIES" switch to "ON" and rotate the "METER SWITCH" to the "L.T." and "H.T." position in turn. The meter should read above the figures marked on the correction label. (If in either case the reading is below the battery pack should be replaced or the range of the set will be curtailed.) The L.T. battery switch at the back of the sender chassis is normally in the "H" position with new batteries. When the L.T. voltage drops below the dotted red line on the test-meter the switch should be thrown over to the "L" position thereby raising the filament voltage by 0.2 volt.

(Mark III). Before using the set for transmission or reception set the meter switch to "L.T:R" and adjust rheostat "R" till the meter reads the number of divisions marked on the panel as corresponding to 2.0 volts. Switch to send with meter switch to L.T:S and repeat with rheostat "S".

Should the set be used at the limit of its useful range, or difficulty experienced with netting procedure, it is occasionally desirable to increase the receiver filament voltage to 2.2 volts, i.e. one scale division on the meter above the value indicated for 2.0 volts.

For economy on battery consumption, receiver current switch (S6A) should be kept at low position, whenever consistent with reasonable communication.

- (e) Open the satchel, remove the microphone, the telephone receivers, and the ground aerial, if required, and insert the appropriate plugs in the jacks marked "MIC" and "PHONES" on the set. Erect the desired aerial and connect to the set.

2. Tuning the sender.

- (a) Put the "BATTERIES" switch to "ON."
- (b) Set the "METER SWITCH" to "AE"
- (c) Release the knurled locking nut at the edge of the "M.O TUNING" handle, carefully setting it to the required frequency. Lock the adjustment by tightening the locking nut.
- (d) Keep the pressel switch on the hand microphone closed throughout the operations (e) to (f) below.
- (e) Adjust the "Ae Tuning" control for maximum aerial current. Vary the position of the "AE SWITCH" and rotate the "AERIAL TUNING" handle alternately until the maximum aerial current is indicated on the test meter.

When the set is used with the ground aerial alone the best position for the "AE SWITCH" is usually on one of the taps 6, 7 or 8.

The instructions in this paragraph refer to the tuning when the vertical aerial or ground aerial or a combination of both is used.

- (f) Speak into the microphone in a normal voice with the microphone held close to the lips. As the set is radiating kicks on the test-meter should be observed.
- (g) Release the pressel switch on the hand microphone.

3. Tuning the receiver.

It is assumed that the "BATTERIES" switch is "ON" and the pressel switch in the microphone handset is released.

- (a) Set the "REC'R TUNING" dial to the frequency of the wanted station. Turn the "L.F. GAIN" control anti-clockwise from its maximum position until the output valve ceases to oscillate. Oscillation is indicated by a rushing noise in the telephones.
- (b) Slowly rotate the "REC'R TUNING" control a little either side of the calibration mark until the required signal is heard. Then carefully adjust this control for maximum signal strength (or with meter switch to MA for maximum dip of meter M/A) if necessary reducing the setting of the "L.F. GAIN" control to permit the "REC'R TUNING" control to be set accurately.

When a C.W. signal is required the "L.F. GAIN" control should be turned clockwise until the output valve just oscillates.

The signal is then tuned as above, the final adjustment of tuning being such that the pitch of the beat note is of a convenient frequency less than 1,000 cycles per second.

- (c) Lock the "REC'R TUNING" control by tightening the knurled nut at the edge of the dial.

4. The netting procedure.

Note.—The term "netting" means the adjustment of a group of stations to a common frequency, so that all stations in the group can intercommunicate freely without the necessity for retuning. In practice one station, usually the headquarters station, becomes the "control station" establishing the group frequency, all the remaining stations in the group netting on (i.e. tuning to) the control station.

- (a) Tune the control station sender to the group frequency in accordance with the instructions given in para. (2) above.
- (b) At the predetermined time the control station calls up the outstations in such a way that they can identify the control station.
- (c) After the preliminary call the control station then radiates C.W. (i.e. unmodulated carrier) for, say, 30 seconds and announces the termination of the netting signal.

During this period each of the outstations in the group proceed as follows:—

- (d) During the preliminary call, the receiver is tuned in to the control station in accordance with para. (3) above. If the signal from the control station is strong operation (c) of para. (3) may be deferred until the end of the netting procedure.
- (e) Keeping the "NETTING SWITCH" fully pressed slowly rotate the "M.O. TUNING" control on the sender either side of the group frequency until a whistle is heard. Then further adjust this control until the pitch of the whistle is as low as possible (i.e. until zero beat frequency is obtained). Lock the "M.O. TUNING" handle at this position. When C.W. is being used the "L.F. GAIN" control should be turned back so that the set does not oscillate during this operation.
- (f) Release the "NETTING SWITCH" and await the announcement of the cessation of the signal from the control station. (This is important. NO outstation must radiate during this period otherwise interference with the other outstations will occur.)
- (g) Press the pressel switch in the microphone handset and tune the sender in the manner indicated in para. (2) without altering the setting of the "M.O. TUNING" handle.

The station is now netted with the control station. The control station operator, however, has not yet tuned his receiver to the group frequency.

- (h) The control station operator now tunes his receiver to the group frequency by either of the following methods:—
- (1) The control station asks for a transmission from one of the outstations, and tunes his receiver to this transmission.
 - or (2) With the control station receiver operating (i.e. pressel switch in Mic. Handset released), the control station sets the "METER SWITCH" to "mA," presses in the NETTING SWITCH and rotates the "REC'R TUNING" handle until a dip is observed in the set meter reading, then carefully adjusting the "REC'R TUNING" handle to give maximum dip on the meter reading.

- Notes.*
- (i) Once the net is established, the control station operator must on no account alter his "M.O. TUNING" control otherwise the whole net will be destroyed. The control station operator may, however, adjust his "REC'R TUNING" control when necessary.
 - (ii) Any operator, other than the control station operator, should check the netting of his station if communication is unsatisfactory.
This is done by pressing the netting switch while listening to the control station. If the whistle then heard has a high pitch, appropriate adjustment of the "M.O. TUNING" dial should be made. It will not be necessary to re-adjust any other sender control.
 - (iii) As an alternative to tuning to zero beat, the receivers may be netted on very strong signals by setting the "METER SWITCH" to "mA" position, and adjusting the "REC'R TUNING" handle to give maximum dip on the meter, care being taken to check by listening in the telephones that netting is being done on the control station signal and not on neighbouring interference.

5. Send-Receive switching.

Having switched the "BATTERIES" switch on, and tuned both sender and receiver in the manner indicated above, send-receive switching is effected entirely by pressing or releasing the switch in the microphone handset. When the switch is pressed the sender operates, whilst releasing the switch operates the receiver.

When using C.W. the send-receive switch embodied in the Key is used.

It is important to allow a second or two when changing from send to receive or vice versa before transmitting the message, otherwise the valve filaments may not be hot and the first few words of the message may not be received.

Note.—Before packing the set after use make sure that the "BATTERY SWITCH" is in the "OFF" position.

6. Mobile Working.

When operation on the move is required, the following procedure is adopted:—

The set is tuned and netted in the manner described above, whilst on the ground. The bottom door flap is then closed, and the microphone and telephone receiver leads are passed over the top of this flap at the right-hand side of the set. The top door flap is then closed on top of these leads, and the retaining straps are fastened across the door flaps. The set may then be carried on the operator's back, and operated in the normal manner. It will be necessary to open the front of the set to switch "OFF" and withdraw the microphone and telephone receivers.

It may be noted that after a relatively long period of working on the move signal strength may fall, due to drifting of the oscillators. This can be remedied by re-netting, either by a second operator whilst the set is still on the first operator's back, or by removing the set from the shoulders and netting with the set on the ground in the normal manner.

7. Operation of mobile sets in the open under fire.

If the operator comes under fire and is compelled to assume a prone position, it may be found that there is a serious fall in signal strength. An increase in signal strength can be effected by restoring the aerial to a vertical position. The aerial is held by the lowest section and rotated towards the vertical until it locks.

When the operator stands upright the aerial should be returned to the original position.

8. Choice of a site for stationary working.

If tactical and other considerations permit, the site chosen should be on high ground, and as far away from trees and telephone wires, etc., as possible. In particular, large metallic objects should be avoided.

If compelled to take cover, use should be made where possible of any facilities offered by the cover for the improvement of the aerial system. This point is dealt with in the section on choice of aerials.

CHAPTER III

AERIALS FOR USE UNDER VARIOUS CONDITIONS

1. The rod aerial and ground aerial.

The aerials normally used with the Wireless Set No. 18 are the rod aerial and ground aerial.

The rod aerial consists of up to twelve sections of copper-plated steel tube which may be mounted on the set to give a self-supporting aerial of 10 ft. maximum height as described in Chapter I, para. (9).

The ground aerial consists of 25 ft. of insulated wire connected to the aerial plug on the set by a socket single at one end. It is intended primarily for working from trenches and other forms of cover where a vertical rod aerial would be too conspicuous.

The ground aerial is thrown along the ground roughly in the direction in which communication is desired. In certain circumstances, as described below, the ground aerial may be used in conjunction with the rod aerial.

The ground aerial is normally carried in the satchel signals with the headphones and hand microphone.

2. Choice of aerial.

The performance of the Wireless Set No. 18 is greatly influenced by the aerial system used. As a general rule the aerial giving greatest range should be employed. For local working, however, the use of the smallest aerial capable of giving adequate signal strength is recommended. This results in less mutual interference with other sets in the locality and also minimises chances of enemy interception.

3. Aerials suitable for use with Wireless Sets No. 18 in open positions.

Under such circumstances use the rod aerials. The mobile sets should use two to six sections, according to range. In the event of working at extended ranges, use may be made of more aerial sections where possible.

An alternative for long range working between stationary sets is to use the ground aerial, either plugged directly into the socket on the side of the set or plugged on the end of three or preferably more sections of vertical rod, the other end of the ground aerial then being

tied as high as possible around any tree, bush or other suitable support. The use of a relatively long section of aerial 6 ft. or more above ground level will very materially increase the range of the sets. This is especially so if both sets are stationary and using the elevated "ground" aerial.

4. Aerials suitable for use with Wireless Sets No. 18 under cover.

The best type of aerial for the forward set will depend on the nature of the cover.

If the set is above ground level, the rod aerial will probably be the best. If working in wooded surroundings it may be possible to attach the ground aerial to the top of the rod aerial and suspend it in the manner indicated in the previous section.

For working from a trench, there are a number of alternatives, the determining factor largely being the range required.

For short range work it may be found that communication is possible with the set standing on the floor of the trench, using the normal four or five section vertical rod aerial.

The range in the above case can usually be very greatly increased by plugging the ground aerial in the top of the rod aerial and suspending it diagonally across the trench, attaching the far end to a wooden spike inserted in the parados.

Finally, the trench aerial may be used in the proper manner, being attached to the sender at one end, and flung out over the parapet so that it lies along the ground. Best results will be obtained if the ground aerial is pointing roughly in the direction from which communication is expected.

5. Aerials for long range use.

For long range working an inverted L aerial of total length not greater than one half wave length should be used. The horizontal part of this aerial should be as high as conveniently possible. It may be constructed of R.5 wire erected between two wooden poles, the bottom of the vertical portion of the aerial being connected to the set by the aerial plug.

If possible these aerials should terminate in a terminal plug to fit in the aerial socket. If such a plug is not available the connection must be made as best it may.

6. Tuning the power amplifier and aerial circuits of the sender when the Wireless Set No. 18 is used with a Wyndom or end-fed horizontal aerial.

For tuning the sender when using a Wyndom or end-fed aerial a tap should be found on the "AE SWITCH" which when tuned by the "AE TUNING" control gives a slight *but definite* dip on the test-meter in "mA" position.

In the case of the Wyndom aerial this tap will probably be one of the lower numbers while in the case of the end-fed aerials the tap will probably be at one of the higher numbers.

To obtain the maximum radiation from these types of aerial critical adjustment of the controls is usually required so that although the above directions will cause the aerial to radiate, further adjustment of the "AE SWITCH" and "AERIAL TUNING" control may be necessary before the aerial is operating efficiently. The final positions may be found by operating a second Wireless Set No. 18 some distance away and manipulating the handles on the first set until the operator of the second set obtains maximum signal strength in his receiver, which is indicated by maximum dip on the test meter with the "METER SWITCH" set at "mA."

7. The use of an earth.

The Wireless Set No. 18 does not normally require an earth connection. In certain circumstances, however, slightly better results may be obtained using a counterpoise earth attached to the earth terminal provided on the left-hand side of the sender case. This earth may be an earth mat, a bunch of wires or any convenient metallic object of large size. If the ground aerial is not in use it may be made to serve as a counterpoise by being connected to the earth terminal and extended on the ground beneath or near the aerial.

If it is found advisable to use a counterpoise earth with the ground aerial an effective method is to connect about 25 ft. of insulated wire to the earth terminal and extend it on the ground in the direction opposite to that of the ground aerial. The straight line formed by the ground aerial and its counterpoise earth should be roughly in the direction of the desired station.

CHAPTER IV MAINTENANCE

I. General maintenance.

The interior of the set should be kept clean and dry and the exterior as free from dirt and wet as circumstances permit. The earth terminal should screw up easily.

(a) *The rod aerial.*

See that the rod aerial sections are either clipped in position on the side of the case or else mounted on the aerial plug. Missing, bent or battered aerial sections must be replaced.

(b) *The ground aerial.*

Examine the ground aerial for breaks and wear, particularly at the point where the wire joins on to the ground aerial terminal. Faulty aerials should be replaced if possible.

(c) *The control panel.*

See that the securing screws which hold the sender and receiver in position in the case unscrew easily.

Examine the locking screws of the control handles. The threads should be free; if tight they should be cleaned and a little thin oil run on the threads.

(d) *The battery compartment.*

It is essential that the battery compartment be kept thoroughly clean, and any corrosion should be removed from the batteries. This is of importance since, if corrosion continues for any length of time, some difficulty will be experienced in removing old batteries for replacement purposes.

(e) *The plugs, sockets and leads.*

Examine the microphone and headphones, plugs and the sockets into which they fit; also the inter-unit plug and socket and the plugs and socket for the Key. They should be kept clean to ensure good contact. Faulty contacts may sometimes be remedied by slightly bending contact springs or opening out split pins a little but these operations should be performed with great care.

Examine the leads for breaks and wear, particularly at the points where they join connecting elements such as plugs, etc.

2. Sender and receiver test figures.

The figures given in the following tables are intended for use as a guide only.

(a) *The test meter and "METER SWITCH."*

Table II gives the readings to be expected from the test meter with the "METER SWITCH" in the various positions and with new batteries in the set. It should be noted that the meter is an indicator only and does not read actual current or voltage values. Actual values should be inserted in the last column.

TABLE II
WIRELESS SETS NO. 18—TEST METER READINGS

"Meter Switch" position	Test Meter Reading	Indication	Actual Values
H.T.	As shown on correction label	H.T. battery voltage.	
L.T.	As shown on correction label	L.T. battery voltage.	
mA	240-270 μ A.	Receiver emission current.	
mA	340-440 μ A.	Sender emission current (Pressel switch depressed).	
mA	310-370 μ A.	Receiver emission current + M.O. emission current ("NET" button depressed).	

(b) *Other test points on the receiver and sender.*

The test figures given in Table III indicate the various figures to be expected from a typical set. The above tests are taken with the set in position in its case and can, therefore, be taken rapidly. For other tests given in the tables below, the sender and receiver will have to be removed from its case. These tests should be taken with an avometer using the ohmmeter section of the instrument and the readings given in Table IV show the resistance to be expected between any two particular points on receiver and sender chassis respectively, anode and screen currents of all valves and base connections.

TABLE III

WIRELESS SET No. 18—VOLTAGE AND CURRENT ANALYSIS AND POINT TO POINT CHECK

V.1.A		ARP 12		V.1.B		ARP 12		V.1.C		V.2.A		V.2.B		AR 8		V.3.A		ATP 4		
Pin	Volts	MA	Resistance To Ohms		Volts	MA	Resistance To Ohms		Volts	MA	Resistance To Ohms	Volts	MA	Resistance To Ohms		Volts	MA	Resistance To Ohms		
			CH.	L.T.+			CH.	L.T.+						CH.	L.T.+			CH.	L.T.+	CH.
1	F+	2	50	(3-5) 0-6	F+	2	50	(4) 0-6	F+	2	50	F-	50	CH.	S.C.	F-	300	CH.	S.C.	1
2	-	-	-	-	-	-	-	2M	-	-	-	-	-	G.B.-	S.C.	-	-	-	H.T.+	2
3	A	144	2-6	1,000	A	144	3-3	H.T.+	1,000	A	150	A	150	H.T.+	7	5	-	-	-	3
4	G2	71	5	50,000	G2	75	9	H.T.+	50,000	-	-	-	-	L.T.+	S.C.	-	-	-	-	4
5	G3	-	-	S.C.	G3	-	-	CH.	S.C.	-	-	D2	-	G.B.-	1M	-	-	-	-	5
6	M	-	-	S.C.	M	-	-	CH.	S.C.	M	-	M	-	CH.	S.C.	M	-	-	-	6
7	-	-	-	-	-	-	-	H.T.+	S.C.	D1	-	D1	-	CH.	0.6M	D1	-	-	-	7
8	F-	-	50	S.C.	F-	-	50	CH.	S.C.	F-	-	F-	50	CH.	S.C.	F+	2	300	CH.	8
Top Cap	G1	-	-	3M	G1	-	-	G.B.-	2M	G1	-	G1	-	CH.	1.1M	G1	152	10-13	H.T.+	Top Cap

TABLE IV-

FROM	TO	RESISTANCE
Pin 1 (L.T.-)	BATTERY PLUG. P2A	Short circuit
Chassis
L.T.-	Rec'r. socket	Short circuit
H.T.-
Pin 5 (L.T.+)	Chassis (Mic. disconnected)	Open circuit
Chassis (Mic. connected and Pressel switch depressed)	..	2.5 ω
L.T.+ Rec'r. socket (Pressel switch normal)	..	1 ω
Pin 4 (H.T.+)	Chassis	Open circuit
H.T.+ Rec'r. socket	..	10-2 ω
R.F. Rec'r. socket	..	10-2 ω
Pin 3 (H.T.+12)	Chassis	Short circuit
H.T.+ Rec'r. socket
L.T.-
Pin 2 (H.T.-)	Chassis	810 ω
G.B.- Rec'r. socket	..	680 ω

TABLE V

FROM	TO	RESISTANCE
MICROPHONE SOCKET. P.1.A.		
Pin 1..	L.T.+ Rec'r. socket	Short circuit
Pin 2..	L.T.+ Battery cable	Short circuit
Pin 3..	Chassis	2 ω
Pin 4..	Chassis	0.5 ω
CONNECTING LEAD (RECEIVER).		
Pin 5 {	Chassis	Short circuit
L.T.-
H.T.-
Pin 3 L.T.+	Chassis	4 ω
Pin 4 H.T.+	Chassis	Open circuit
Pin 1 R.F.:	Chassis	Open circuit
Pin 2 G.B.-	Chassis	Open circuit
PHONE JACK.		
Chassis	Chassis	Open circuit
Chassis	Chassis	5 ω

All voltages measured with 1,000 ohms per volt voltmeter. Figures given are the average of 6 sets of valves in a typical receiver. CH. = Chassis. S.C. = Short Circuit. Figures in brackets are for Mark I and II only.

TABLE
WIRELESS SET NO. 18—VOLTAGE AND CURR

V.I.A					V.I.B					V.I.C				
ARP 12					ARP 12					ARP 12				
														
Pin		Volts	MA	Resistance To Ohms		Volts	MA	Resistance To Ohms		Volts	MA	Resistance To Ohms		
1	F+	2	50	CH. (3.5) L.T.+ 0-6	F+	2	50	CH. (7.5) L.T.+ 0-6	F+	2	50	CH. (4) L.T.+ 0-6		
2	—	—	—	—	—	—	—	L.T.+ S.C.	—	—	—	G.B.— 2M		
3	A	144	2.6	H.T.+ 1,000	A	144	3.3	H.T.+ 1,000	A	152	2.7	H.T.+ 7		
4	G2	71	.5	H.T.+ 50,000	G2	75	.9	H.T.+ 70,000	G2	73	.6	H.T.+ 50,000		
5	G3	—	—	CH. S.C.	G3	—	—	CH. S.C.	G3	—	—	CH. S.C.		
6	M	—	—	CH. S.C.	M	—	—	CH. S.C.	M	—	—	CH. S.C.		
7	—	—	—	—	—	—	—	H.T.+ S.C.	—	—	—	H.T.+ S.C.		
8	F—	—	50	CH. S.C.	F—	—	50	CH. S.C.	F—	—	50	CH. S.C.		
Top Cap	G1	—	—	G.B.— 3M	G1	—	—	CH. 0.5 M	G1	—	—	G.B.— 2M		

TABLE IV

FROM	TO	RESISTANCE
	BATTERY PLUG. P2A	
Pin 1 (L.T.—)	Chassis	Short circuit
	L.T.— } Rec'r. socket	Short circuit
	H.T.— }	
Pin 5 (L.T.+)	Chassis (Mic. disconnected)	Open circuit
	Chassis (Mic. connected and Pressel switch depressed)	2.5 ω
	L.T.+ Rec'r. socket (Pressel switch normal) ..	1 ω
Pin 4 (H.T.+)	Chassis	Open circuit
	H.T.+ Rec'r. socket	10.2 ω
	R.F. Rec'r. socket	10.2 ω
Pin 3 (H.T.+12)	Chassis	Short circuit
	H.T.— } Rec'r. socket	Short circuit
	L.T.— }	
Pin 2 (H.T.—)	Chassis	810 ω
	G.B.— Rec'r. socket	680 ω

All voltages measured with 1,000 ohm
Figures given are the average of 6 sets
CH. = Chassis.
S.C. = Short Circuit.
Figures in brackets are for Mark I and

TABLE III

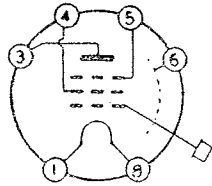
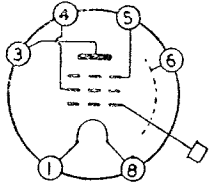
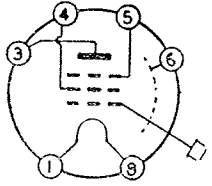
CURRENT ANALYSIS AND POINT TO POINT CHECK

Resistance Ohms	V.2.A AR 8				V.2.B AR 8				V.3.A ATP 4							
	Volts	MA	Resistance To Ohms		Volts	MA	Resistance To Ohms		Volts	MA	Resistance To Ohms		Pin			
(4) 0-6	F+	2	50	CH. L.T. +	(3.5) 0-6	F-	—	50	CH.	S.C.	F-	—	300	CH.	S.C.	1
2M	—	—	—	G.B.-	S.C.	—	—	—	G.B.-	S.C.	—	—	—	H.T.+	10.2	2
7	A	150	2.6	H.T.+	7	A	150	5	H.T.+	1,000	—	—	—	—	—	3
50,000	—	—	—	L.T. +	S.C.	—	—	—	G.B.-	S.C.	G2	152	2-3	H.T.+	10.2	4
S.C.	D2	—	—	G.B.-	1M	D2	—	25μA	G.B.-	0.5 M	G1	—	—	G.B.- CH.	1.1 M O.C.	5
S.C.	M	—	—	CH.	S.C.	M	—	—	CH.	S.C.	—	—	—	G.B.-	0.6 M	6
S.C.	D1	—	—	CH.	0.6 M	D1	—	—	CH.	S.C.	—	—	—	—	—	7
S.C.	F-	—	50	CH.	S.C.	F+	2	50	CH.	(5) 0-6	F+	2	300	CH.	(1.5) 0-6	8
2M	G1	—	—	G.B.- VC Max. VC Min.	1.1 M 0.1 M	G1	—	—	CH.	50,000	A	152	10-13	H.T.+	10.2	Top Cap

TABLE V

FROM	TO	RESISTANCE
MICROPHONE SOCKET. P.1.A.		
Pin 1	L.T.+ Rec'r. socket ..	Short circuit
Pin 2	L.T.+ Battery cable ..	Short circuit
Pin 3	Chassis	2ω
Pin 4	Chassis	0.5ω
CONNECTING LEAD (RECEIVER).		
Pin 5 { L.T. - H.T. - } ..	Chassis	Short circuit
Pin 3 L.T.+ ..	Chassis	4ω
Pin 4 H.T.+ ..	Chassis	Open circuit
Pin 1 R.F... ..	Chassis	Open circuit
Pin 2 G.B.- ..	Chassis	Open circuit
PHONE JACK.		
Either Contact ..	Chassis	Open circuit
Between Contacts ..	Chassis	5ω

1,000 ohms per volt voltmeter.
e of 6 sets of valves in a typical receiver.

Mark I and II only.

- (c) *Receiver sensitivity tests* (to be performed by skilled personnel only).

If suitable apparatus is available the gain of succeeding stages may be measured. Sender, receiver and battery pack should be removed from case and laid on their sides when they can readily be connected up for operation.

- (i) A.F. stages.

With 1 volt of 400 c/s applied to the grid of the A.F. valve, an output of 3-4 milliwatts should be obtained. The "L.F. GAIN" control for this test should be set just short of the oscillating condition.

- (ii) I.F. stages.

With a signal input of 250-350 microvolts of I.F. frequency 465Kc/s, which is modulated at 400 c/s to a depth of 30%, applied to the F.C. grid, an output of 1 milliwatt should be obtained.

- (iii) Overall sensitivity.

With a signal input of 2.5-7 microvolts modulated at 400 c/s to a depth of 30%, an output of 1 milliwatt should be obtained over the tuning range, using a dummy aerial of 50 $\mu\mu\text{F}$ capacity.

3. Fault location.

The presence of a fault may be indicated by the meter showing an unusual reading. Before any part of the set is dismantled the fault should be localised as far as possible. Before beginning to trace a fault, make sure that the controls have been adjusted in accordance with the working instructions.

Measurements other than those made with the set test meter, should preferably be carried out with an Avometer.

For continuity testing a pair of the low resistance headphones may be used in conjunction with the 3-volt L.T. battery.

The test meter on the sender control panel should not be used for continuity or any tests other than those in connection with the "METER SWITCH."

If it is suspected that the meter circuit is faulty it should first be tested for continuity either with an ohmmeter or with telephones as described above. Unless the meter circuit is in order many of the tests given in the following tables will give negative results.

The tests may be performed in the order in which they appear in the tables.

Important Note.

In the following sections infantry battalion personnel should confine itself to those tests which deal with batteries, with the test meter and with the headphones and microphone. The internal wiring and components of the set should not be touched.

(a) Sender faults.

TABLE VI
SENDER FAULTS

Symptom (1)	Possible Fault (2)	Remedy (3)
1. No. H.T. or L.T. shown by no reading on test meter with "METER SWITCH" in "H.T." and "L.T." positions.	(a) Faulty L.T. or H.T. connections.	Check L.T. and H.T. leads for breaks and see that terminal connections are clean and tight.
	(b) One or both batteries run down.	Replace the batteries concerned.
	(c) Faulty meter.	Try a new meter.
	(d) Faulty meter circuit.	Check through meter circuit.
	(e) Faulty "BATTERY SWITCH."	Check connections to switch. Replace switch if necessary.
2. Low or no anode current in valves shown by test meter when "METER SWITCH" is in "mA" position.	(a) Faulty valves.	Replace valves concerned and test the anode currents with the test meter. The A.T.P.4 filament can be seen as a dull red glow under operating conditions. Separate reading for M.O. anode current is obtained by pressing "NET" switch.
	(b) Faulty meter circuit.	Examine and clean, if necessary, "METER SWITCH" contacts. Check meter circuit for burnt out resistors and disconnections. Repair circuit renewing faulty components.
	(c) Faulty filament circuits.	Test by first removing valves from sender and closing Pressel switch on hand microphone. Test across filament sockets of the valves with one of the following:—Voltmeter (Avo-meter No. 7) headphones or 3 volt. miniature bulb. The filament socket numbers and voltages are as follows: V5—socket Nos. 1 & 8— (-ve) 2.4-3.1 volts.

TABLE VI—continued

Symptom (1)	Possible Fault (2)	Remedy (3)
3. No aerial current but dip in receiver current on Tuning the M.O. with "NET" switch depressed.	<p>(d) Faulty H.T. circuits.</p> <p>(a) Faulty meter switch.</p> <p>(b) Faulty instrument rectifier.</p> <p>(c) Faulty wiring in meter transformer.</p>	<p>V6—socket Nos. 1 (-ve) & 8 2.4-3.1 volts. If no L.T. on valve sockets check through L.T. circuits, examine netting switch for dirty or bent springs. Bend springs <i>on filament side only</i> to normal with tool and repair circuit replacing faulty components.</p> <p><i>Note</i> : If the netting compensation condenser spring contacts are touched the netting compensation will be seriously affected.</p> <p>If tests for faults (a), (b) and (c) above prove negative then the fault probably lies in the H.T. circuit which should be examined for burnt out components, dry joints, etc., and repaired.</p> <p>See that contacts of the "METER SWITCH" in the "Æ CURRENT" position are clean and making good contact. If the switch contacts are very much bent renew the switch.</p>
4. Little or no aerial current indicated on test meter.	<p>(a) Aerial spring at side of sender not making good contact with aerial.</p> <p>(b) Faulty connection through rotatable aerial plug.</p> <p>(c) Faulty "AERIAL SWITCH."</p>	<p>Bend spring to make necessary contact. If this cannot be done renew spring.</p> <p>Examine and repair if necessary connections in the rotatable aerial socket.</p> <p>Examine contacts. Clean and bend them if necessary. If no improvement renew the switch.</p>

TABLE VI—continued

Symptom (1)	Possible Fault (2)	Remedy (3)
5. Master oscillator not oscillating (shown by setting "METER SWITCH" to "mA." when a high reading will be observed.	(a) Faulty connections or components in master oscillator circuit.	Check connections in following order to: i. Variable condenser for short circuit. ii. Trimmer condensers for short circuit. iii. Netting compensation circuit. iv. Remainder of master oscillator circuit. If the wiring of these circuits is correct test individual components.
6. No kick on test meter with "METER SWITCH" in "Æ CURRENT" position and speech in microphone.	(a) No polarising voltage on microphone.	Remove capsule from holder. With Pressel switch closed <i>momentarily</i> short capsule contacts in holder. If test meter shows rise microphone circuit is in order.
	(b) Faulty microphone lead.	Check continuity of leads.
	(c) Faulty gas-mask microphone jack.	Examine gas mask microphone jack for dirt and bent springs. Repair or replace if necessary.
	(d) Faulty microphone transformer.	Check continuity of primary and secondary windings. Connect headphones across secondary of microphone transformer and speak into mike with pressel switch closed. If speech is heard in headphones the microphone transformer is in order. If no speech is heard replace the transformer.
7. No heterodyne whistle audible on netting.	(e) No bias on control grid of P.A.	Check resistance of grid circuit to G.B.—Check insulator of microphone transformer.
	(a) Disconnection in netting switch or associated circuits.	Set "METER SWITCH" to "mA" and press the netting switch. No reading on test meter indicates disconnection in netting circuit. In this case remove master oscillator valve and with

TABLE VI—*continued*

Symptom (1)	Possible Fault (2)	Remedy (3)
<p>8. Consistently inaccurate netting transmitted frequency always a fixed number of kc/s more or less than the frequency of the netting signal for any given signal frequency.</p>	<p>(a) Netting compensation condenser disconnected or out of adjustment.</p>	<p>Pressel switch on hand microphone open and netting switch closed test for L.T. across pins 1 (-ve) and 8 (+ve) of M.O. valve holder. If no L.T. voltage examine netting switch contacts and check through sender netting circuit.</p> <p>Check by netting with another Wireless Set No. 18 known to be in good order noting how much the receiver of the latter has to be retuned to give maximum volume. (Tune with "METER SWITCH" at "mA" by turning the "REC'R TUNING" control of the receiver until the test meter is at maximum dip). Examine connections to netting condenser and repair if broken. If netting condenser is out of adjustment arrangements should be made to have the readjustment made as soon as possible. It should not be attempted in the field. Instructions for the above adjustment are given in para. (4a) below.</p>

(b) *Receiver faults.*

Although it is desirable to have suitable instruments for testing a faulty receiver, the defective units of the receiver circuit may be often located quite simply by the following procedure:—

- (i) Put the "BATTERY SWITCH" to "ON," plug in the 'phones and listen carefully.
- (ii) Touch with a metal rod or moist finger the grid cap of V₄, when a heavy "plonk" (and possibly hum from A.C. mains, if these are near by) will be heard, in the 'phones. For this test the gain control must be set to a maximum. If no sound or a weak sound is heard V₄ should be replaced and the associated components checked.

- (iii) Proceed as in (ii) touching the grid cap of V₃ when a metallic "click" should be heard in the 'phones. If no sound or a very weak sound is heard V₃ should be replaced and the associated components checked.
- (iv) Proceed as in (iii) touching the grid cap of V₂ when a metallic "click" will be heard but will be louder than in case (ii). If no sound or a weak sound is obtained V₂ should be replaced and the associated components checked.
- (v) Proceed as in (ii) touching the grid cap of V₁ when a "click" should be heard in the 'phones. If no "click" or a very weak "click" is heard the valve should be replaced and the associated components checked.

If the R.F. unit is in order check the aerial circuit carefully.

If an Avometer No. 7, a Megger and a soldering iron are available, the table below, together with Tables III, IV and V in para. (2), should be used in order to locate a simple fault on a receiver.

Using the Avometer as an ohmmeter, and the circuit diagram, the continuity of coils in the aerial, anode oscillator and I.F. transformers may be checked.

TABLE VII
RECEIVER FAULTS

Symptom (1)	Possible Fault (2)	Remedy (3)
1. No signals; no reading on test meter with "METER SWITCH" in "L.T." or "H.T." positions.	(a) Faulty L.T. or H.T. connections.	Check L.T. and H.T. leads for breaks and see that terminal connections are clean and tight.
	(b) One or both batteries run down.	Replace the batteries.
	(c) Faulty meter.	Try a new meter.
	(d) Faulty meter circuit.	Check through meter circuit.
	(e) Faulty "BATTERIES" switch on sender.	Check connections to "BATTERIES" switch; replace if necessary.
2. No signals; test meter reads in "L.T." and "H.T." positions.	(a) Faulty L.T. or H.T. connections between sender and receiver.	Switch set off and examine connections. See that the plug and socket are clean and making good contact.
	(b) Faulty valves.	Replace the valves concerned.

TABLE VII—continued

Symptom (1)	Possible Fault (2)	Remedy (3)
3. No signals; intermittent or low valve current reading on test meter.	(c) No. H.T. or L.T. on valves.	Check connections to valveholders (see Table III).
	(a) Valve loose in holder.	Push firmly "home" in holder.
4. No signals.	(a) Grid cap not in position on valve or broken flexible connection to grid cap.	Replace or test for continuity of flexible connector.
	(b) Local oscillator stage not oscillating.	Test for internal fault in R.F. and local oscillator using Table III in para. 2, "Sender and receiver test figures" above.
5. No signals; oscillator working correctly.	(a) Short circuit or disconnection in leads to telephone sockets or fault in socket itself.	Examine wiring and telephone sockets.
	(b) Faulty connections to grid of VI in cable between sender and receiver units.	Check continuity and insulation.
	(c) Short circuit or open circuit in wiring.	See para. (2), "Sender and receiver test figures" Table III giving point to point resistance measurements on each valveholder.
6. Weak signals.	(a) Valve or valves require replacement.	See if valve current is less than that given in Table II (para. 2, "Sender and receiver test figures"). Change if necessary.
7. Distortion of loud signals.	(a) No A.V.C.	Check resistances from grid caps of VI and V3 to G.B.—plug.
8. "Motor boating" (popping noise in phones).	(a) A.V.C. decoupling condensers disconnected.	Connect a 0.1 μ F condenser in parallel with each decoupling condenser in turn.
9. "Motor boating" (popping noise in phones) or instability.	(a) H.T. decoupling condensers disconnected.	See (8) above.
	(b) 0.1 μ F L.T. decoupling condenser disconnected or faulty.	Connect in circuit again, or replace.

TABLE IX
WIRELESS SETS No. 18 Mark I and II
COMPONENTS

Schematic Reference	Designation
	Inductances
L.1.A	Wireless sets No. 18, inductances, receiver aerial tuning (ZN 2114).
L.2.A* } L.2.B* } L.2.C* }	Wireless sets No. 18, inductances, 1st oscillator tuning (comprising 2 reaction coils and het. oscillator coil, wound on one former (ZN 2115)).
L.3.A* } L.3.B* }	Wireless sets No. 18, inductances, power amplifier tuning (ZN 2116). (Comprising P.A. tuned anode coil and neutralising coupler wound on one former.)
L.4.A* } L.4.B* }	Wireless sets No. 18, inductances, M.O. tuning (ZN 2117). (Comprising M.O. tuning coil and reaction coil wound on same former.)
L.5.A	Wireless sets No. 18, inductances, 1st I.F. (ZN 2118).
L.6.A	Wireless sets No. 18, inductances, 2nd I.F. (ZN 2119).
L.7.A†	Wireless sets No. 18, inductances Beat oscillator (ZN 2161).
	Transformers
T.1.A	Transformers, telephone No. 10 (ZA 5135).
T.2.A	Wireless sets No. 18, transformers, aerial current metering (ZN 2140).
T.3.A	Transformers, microphone No. 6 (ZA 5134).
	Switches
S.1.A	Switches, rotary disc, S.P. 8-position, No. 1 (aerial tapping switch) (ZA 5136).
S.2.A	Switches, rotary disc 2-pole, 5-position, No. 3 (meter switch) (ZA 5137).
S.3.A	Keys, No. 228, White (netting switch) (YA 0906).
S.4.A—B	Switches, on-off, D.P. No. 1 (battery on-off switch) (ZA 8723).
S.5.A	Microphones, hand No. 4 Switches, Pressel (used on microphones, hand No. 4).
	Valves
V.1.A } V.1.B } V.1.C }	Valves W.T. type A.R.P.12 (ZA 7023).

TABLE IX—continued

Schematic Reference	Designation
V.2.A } V.2.B } V.3.A	Valves, W.T. type A.R.8 (ZA 7022). Valves, W.T. type A.T.P.4 (ZA 5502).
P.1.A P.2.A* P.3.A*	Plugs Plugs, 4-point, No. 7 (ZA 5559). 5-point plug on battery lead. 5-point plug on inter-unit connection lead.
J.1.A J.2.A J.3.A†	Jacks Jacks, microphone No. 2 (ZA 4394) Jacks, telephone, No. 2 (ZA4390). Jacks, microphone No. 4A (ZA4355).
P.4.A	Sockets Sockets, 5-point, No. 1 (ZA 5138).
K.1.A†	Keys Key and plug assembly No. 8 (ZA4354).
W.1.A W.2.A	Rectifiers Rectifiers, metal, W.1 (ZA 4921). Rectifiers, selenium, No. 2 (ZA 4920).
C.1.A—H C.2.A C.3.A C.4.A C.5.A C.6.A—B C.7.A—D C.8.A C.9.A C.10.A C.11.A—C C.12.A C.13.A—B C.14.A—B C.15.A—F	Condensers Condensers, P.1.U ($\cdot 1\mu\text{F}$) (ZA 1588) Condensers, Q.5.E ($\cdot 05\mu\text{F}$) (ZA 1589). Condensers, R.2.L ($\cdot 002\mu\text{F}$) (ZA 1591). Condensers, R.5.D ($\cdot 005\mu\text{F}$) (ZA 1363). Condensers, X.1.J ($\cdot 0001\mu\text{F}$) (ZA 1439). Condensers, X.1.N ($\cdot 0001\mu\text{F}$) (ZA 1592). Condensers, X.5.J ($\cdot 0005\mu\text{F}$) (ZA 1441). Condensers, Y.2.G ($\cdot 00002\mu\text{F}$) (ZA 1593). Condensers, Y.45.B ($\cdot 000045\mu\text{F}$) (ZA 1594). Condensers, Y.5.G ($\cdot 00005\mu\text{F}$) (ZA 1595). Condensers, Q.25.A ($\cdot 025\mu\text{F}$) (ZA 1596). Condensers, Y.3.F ($\cdot 00003\mu\text{F}$) (ZA 1597). Condensers, Z.5.E. ($\cdot 000005\mu\text{F}$) (ZA 1640). Condensers, variable, 2-gang X.127.A ($\cdot 000127\mu\text{F}$ each section) (ZA 1608). Condensers, semi-fixed, Y.15.B ($\cdot 000015\mu\text{F}$ max.).

TABLE IX—*continued*

Schematic Reference	Designation
C.16.A	Condensers, Y.8.B ($\cdot 00008\mu\text{F}$) (ZA 1601).
C.17.A	Condensers, Y.9.A ($\cdot 00009\mu\text{F}$) (ZA 1602).
C.18.A	Condensers, X.13.A ($\cdot 00013\mu\text{F}$) (ZA 1603).
C.19.A	Condensers, X.14.A ($\cdot 00014\mu\text{F}$) (ZA 1604).
C.20.A	Condensers, variable, X.127.A ($\cdot 000127\mu\text{F}$ max.) (ZA 1606).
C.21.A	Condensers, variable, X.15.B ($\cdot 00015\mu\text{F}$ max.) (ZA 1607).
C.22.A§	Condensers, Y.1.C ($\cdot 00001\mu\text{F}$) (ZA 1643).
C.23.A†	Condensers, R.1.Z ($\cdot 001\mu\text{F}$) (ZA 1638).
C.24.A†	Condensers, X.11.A ($\cdot 00011\mu\text{F}$) (ZA 1639).
C.25.A†	Condensers, Z.3.B ($\cdot 000003\mu\text{F}$) (ZA 1598).
Resistors	
R.1.A—C	Resistors, No. 3A, $\frac{1}{4}$ -watt 1·1 megohms (ZA 5048).
R.2.A—C	Resistors, No. 3A, $\frac{1}{4}$ -watt 1000 ohms (ZA 5043).
R.3.A	Resistors, No. 3A, $\frac{1}{4}$ -watt 70,000 ohms (ZA 5045).
(R.4.C.†) R.4.A—C	Resistors, No. 3A, $\frac{1}{4}$ -watt 50,000 ohms (ZA 5044).
R.5.A—E	Resistors, No. 3A, $\frac{1}{4}$ -watt 510,000 ohms (ZA 5047).
R.6.A—C	Resistors, No. 3A, $\frac{1}{4}$ -watt 110,000 ohms (ZA 5046).
R.7.A	Resistances, variable, 1 megohm No. 1 (ZA 5077).
R.8.A—B	Resistances, 1·6 ohms, No. 1 (ZA 4202).
R.9.A	Resistances, 4·5 ohms, No. 1 (ZA 4203).
R.10.A	Resistors, No. 3A, $\frac{1}{4}$ -watt 400 ohms (ZA 4931).
R.11.A	Resistors, No. 3A, $\frac{1}{4}$ -watt 25 ohms (ZA 4930).
R.12.A	Resistances, 10·2 ohms, No. 1 (ZA 5040).
R.13.A	Wireless sets No. 18, resistances, 0·9 ohms (ZN 2107). [Resistances 0·3 ohms ZN 2103].
R.14.A	Resistors, No. 3A, $\frac{1}{4}$ -watt 100 ohms (ZA 5041).
R.15.A	Resistors, No. 3B, $\frac{1}{4}$ -watt 500,000 ohms (ZA 3146).
R.16.A	Resistors, No. 3B, $\frac{1}{4}$ -watt 9500 ohms $\pm 5\%$ (ZA 12842).
R.17.A	Resistors, No. 3A, $\frac{1}{4}$ -watt 130 ohms (ZA 4928).
R.18.A	Resistors, No. 3A, $\frac{1}{4}$ -watt 680 ohms (ZA 4843).
R.20.A	Resistances, 1·6 ohms No. 1 (ZA 4202).

* Not separately demandable.

† Not used on Wireless Sets No. 18 Mark I.

§ Omitted on some sets.

|| In some cases 5% tolerance is obtained by series—parallel arrangement of resistors.

Note. Refer to Prefatory Note p. 4 for differences between Wireless Sets No. 18 Mark I Nos. 0001—0250 and Wireless Sets No. 18 Mark I Nos. 0251—1000.

WIRELESS SETS NO. 18 Mark III

Circuit Indication	
	Inductances
L.1.A	Wireless sets No. 18, inductances, receiver aerial tuning (ZN 2114).
L.2.A* } L.2.B* } L.2.C* }	Wireless sets No. 18, inductances, 1st oscillator tuning (comprising 2 reaction coils and het oscillator coil, wound on one former) (ZN 2115).
L.3.A* } L.3.B* }	Wireless sets No. 18, inductances, power amplifier tuning (ZN 2116). (Comprising P.A. tuned anode coil and neutralising coupler wound on one former.)
L.4.A* } L.4.B* }	Wireless sets No. 18, inductances, M.O. tuning (ZN 2117). (Comprising M.O. tuning coil and reaction coil wound on same former.)
L.5.A	Wireless sets No. 18, inductances, 1st I.F. (ZN 2118).
L.6.A	Wireless sets No. 18, inductances, 2nd I.F. (ZN 2119).
L.7.A†	Wireless sets No. 18, inductances. Beat oscillator (ZN 2161).
	Transformers
T.1.A	Transformers, telephone No. 10 (ZA 5135).
T.2.A	Wireless sets No. 18, transformers, aerial current metering (ZA 2140).
T.3.A	Transformers, microphone No. 6 (ZA 5134).
	Switches
S.1.A	Switches, rotary disc, S.P. 8-position, No. 1 (aerial tapping switch) (ZA 5136).
S.3.A	Keys, No. 228, white (netting switch) (YA 0906).
S.4.A	Switch "on-off," D.P. No. 1 (battery on-off switch) (ZA 8723).
S.4.B§	Switches, on-off, D.P. No. 1 (battery on-off switch) (ZA 8723).
S.5.A*	Microphones, hand No. 4 switches, pressel (used on microphones, hand No. 4).
S.6.A.	Switches, rotary disc, 2-pole, 6-position, No. 3 (meter switch) (ZA 5137).
S.4.C	Sensitivity switch (Switches, on-off S.P. No. Z ZA 8724).
	Valves
V.1.A } V.1.B } V.1.C }	Valves, W.T. type A.R.P.12 (ZA 7023).

WIRELESS SETS No. 18 Mark III—*continued*

Circuit Indication	
V.2.A } V.2.B } V.3.A	Valves, W.T. type A.R.8 (ZA 7022). Valves, W.T. type A.T.P.4 (ZA 5502).
P.1.A P.2.A* P.3.A*	Plugs Plugs, 4-point, No. 7 (ZA 5559). 5-point plug on battery lead. 5-point plug on inter-unit connection lead
J.1.A J.2.A J.3.A†	Jacks Jacks, microphone No. 2 (ZA 4394). Jacks, telephone No. 2 (ZA 4390). Jacks, microphone No. 4A (ZA 4355).
P.4.A	Sockets Sockets, 5-point, No. 1 (ZA 5138).
K.1.A	Keys Key and plug assembly No. 8 (ZA 4354)
W.1.A W.2.A	Rectifiers Rectifiers, metal, W.1 (ZA 4921). Rectifiers, selenium, No. 2 (ZA 4920).
C.1.A—H C.2.A C.3.A C.4.A C.5.A C.6.A—B C.7.A—D C.8.A C.9.A C.10.A—B C.11.A—C C.12.A C.13.A C.14.A C.15.A—F	Condensers Condensers, P.1.U ($\cdot 1\mu\text{F}$) (ZA 1588). Condensers, Q.5.E ($\cdot 05\mu\text{F}$) (ZA 1589). Condensers, R.2.L ($\cdot 002\mu\text{F}$) (ZA 1591). Condensers, R.5.D ($\cdot 005\mu\text{F}$) (ZA 1363). Condensers, X.1.J ($\cdot 0001\mu\text{F}$) (ZA 1439). Condensers, X.1.N ($\cdot 0001\mu\text{F}$) (ZA 1592). Condensers, X.5.J ($\cdot 0005\mu\text{F}$) (ZA 1441). Condensers, Y.2.G ($\cdot 00002\mu\text{F}$) (ZA 1593). Condensers, Y.45.B ($\cdot 000045\mu\text{F}$) (ZA 1594). Condensers, Y.5.G ($\cdot 00005\mu\text{F}$) (ZA 1595). Condensers, Q.25.A ($\cdot 025\mu\text{F}$) (ZA 1596). Condensers, Y.3.F ($\cdot 00003\mu\text{F}$) (ZA 1597). Condensers, Z.5.E ($\cdot 000005\mu\text{F}$) (ZA 1640). Condensers, variable 2-gang X.127.A ($0\cdot 000127\mu\text{F}$ each section) (ZA 1608). Condensers, semi-fixed, Y.15.B ($\cdot 000015\mu\text{F}$ max.).

WIRELESS SETS No. 18 Mark III—*continued*

Circuit Indication	
C.16.A	Condensers, Y.8.B ($\cdot 00008\mu\text{F}$) (ZA 1601).
C.17.A	Condensers, Y.9.A ($\cdot 00009\mu\text{F}$) (ZA 1602).
C.18.A	Condensers, X.13.A ($\cdot 00013\mu\text{F}$) (ZA 1603).
C.19.A	Condensers, X.14.A ($\cdot 00014\mu\text{F}$) (ZA 1604).
C.20.A	Condensers, variable, X.127.A ($\cdot 000127\mu\text{F}$ max.) (ZA 1606).
C.21.A	Condensers, variable, X.15.B ($\cdot 00015\mu\text{F}$ max) (ZA 1607).
C.22.A†	Condensers, Y.1.C ($\cdot 00001\mu\text{F}$) (ZA 1643).
C.23.A—B†	Condensers, R.1.Z ($\cdot 001\mu\text{F}$) (ZA 1638).
C.24.A†	Condensers, X.11.A ($\cdot 00011\mu\text{F}$) (ZA 1639).
C.25.A†	Condensers, Z.3.B ($\cdot 000003\mu\text{F}$) (ZA 1598).
C.22.B	Condensers, Y.1.C ($\cdot 00001\mu\text{F}$) (ZA 1643).
	Resistors
(R.I.D. ‡) R.1.A—D	Resistors, No. 3A, $\frac{1}{4}$ -watt 1·0 megohms (ZA 3833)
R.2.A—C	Resistors, No. 3 A, $\frac{1}{4}$ -watt 1000 ohms (ZA 5043).
R.3.A	Resistors, No. 3A, $\frac{1}{4}$ -watt 70,000 ohms (ZA 5045).
R.4.A—C	Resistors, No. 3A, $\frac{1}{4}$ -watt 50,000 ohms (ZA 5044).
R.5.A—E	Resistors, No. 3A, $\frac{1}{4}$ -watt 500,000 ohms (ZA 3832).
R.6.A—C	Resistors, No. 3A, $\frac{1}{4}$ -watt 100,000 ohms (ZA 3831).
R.7.A	Resistances, variable, 1 megohm No. 1 (ZA 5077).
R.10.A	Resistors, No. 3A, $\frac{1}{4}$ -watt 400 ohms (ZA 4931).
R.11.A	Resistors, No. 3A, $\frac{1}{4}$ -watt 25 ohms (ZA 4930).
R.12.A	Resistances, 10·2 ohms, No. 1 (ZA 5040).
R.14.A	Resistors, No. 3A, $\frac{1}{4}$ -watt 100 ohms (ZA 5041)
R.15.A	Resistors, No. 3B, $\frac{1}{4}$ -watt 500,000 ohms (ZA 3146).
R.16.A	Resistors, No. 3B, $\frac{1}{4}$ -watt 9,500 ohms $\pm 5\%$ (ZA 12842).
R.17.A	Resistors, No. 3A, $\frac{1}{4}$ -watt 130 ohms (ZA 4928).
R.18.A	Resistors, No. 3A, $\frac{1}{4}$ -watt 680 ohms (ZA 4843).
R.21.A—B	Resistances, variable, 6 Ω , No. 2 (ZA 3241).
R.22.A	Resistors, No. 3A, $\frac{1}{4}$ -watt, 5000 ohms (ZA 3242).
R.23.A	Resistors, 8 ohms, No. 1 (ZA 5039), Ser. No. 5720 onwards.
M.1.A	Wireless sets No. 18, meters testing (ZA 2106).

* Not separately demandable.

† Not used on Wireless Sets No. 18 Mark I.

‡ Omitted on some sets.

§ Not used on Mark III.

|| In some cases $\pm 5\%$ tolerance is obtained by using series parallel arrangement of resistors.

WIRELESS SET No. 18 MARK III

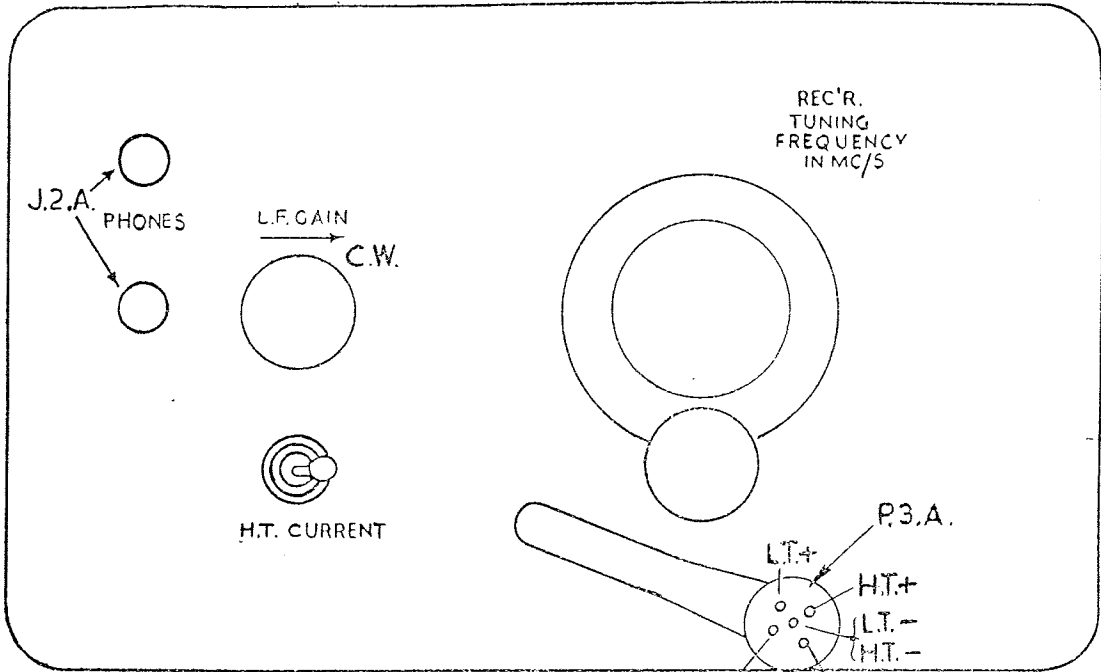
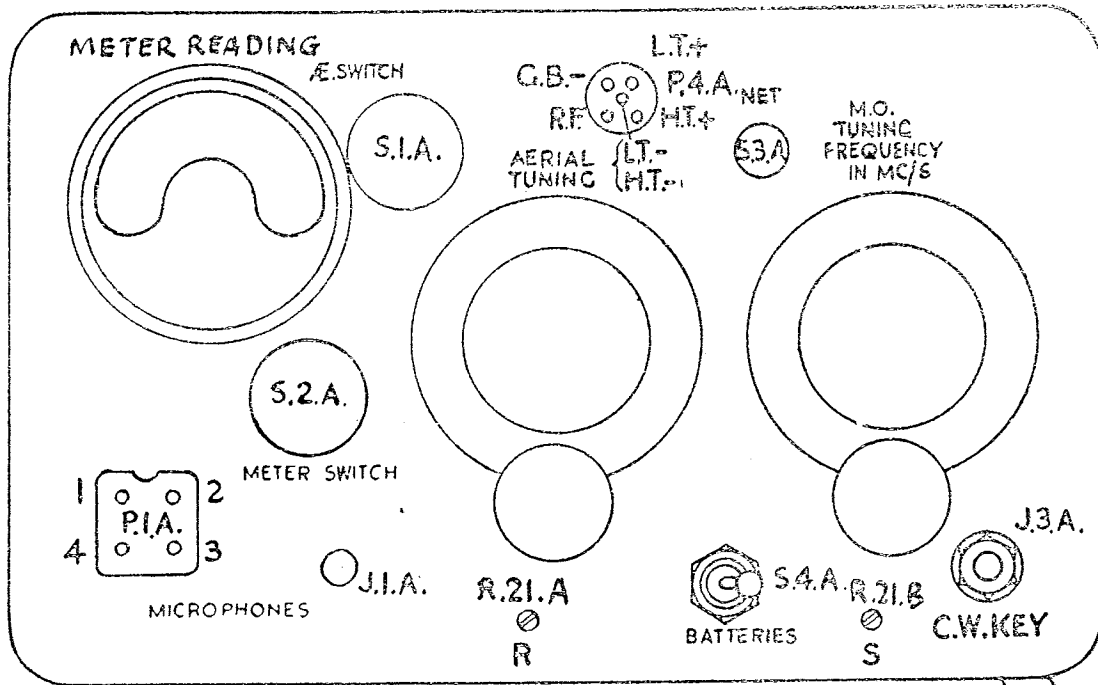
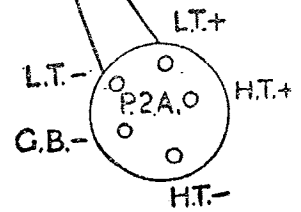

FIG. 1. FRONT VIEW OF RECEIVER PANEL



J3A, OMITTED ON WS. No.18 MARK I

FIG. 2. FRONT VIEW OF SENDER PANEL



WIRELESS SET NO. 18 MARK III RECEIVER

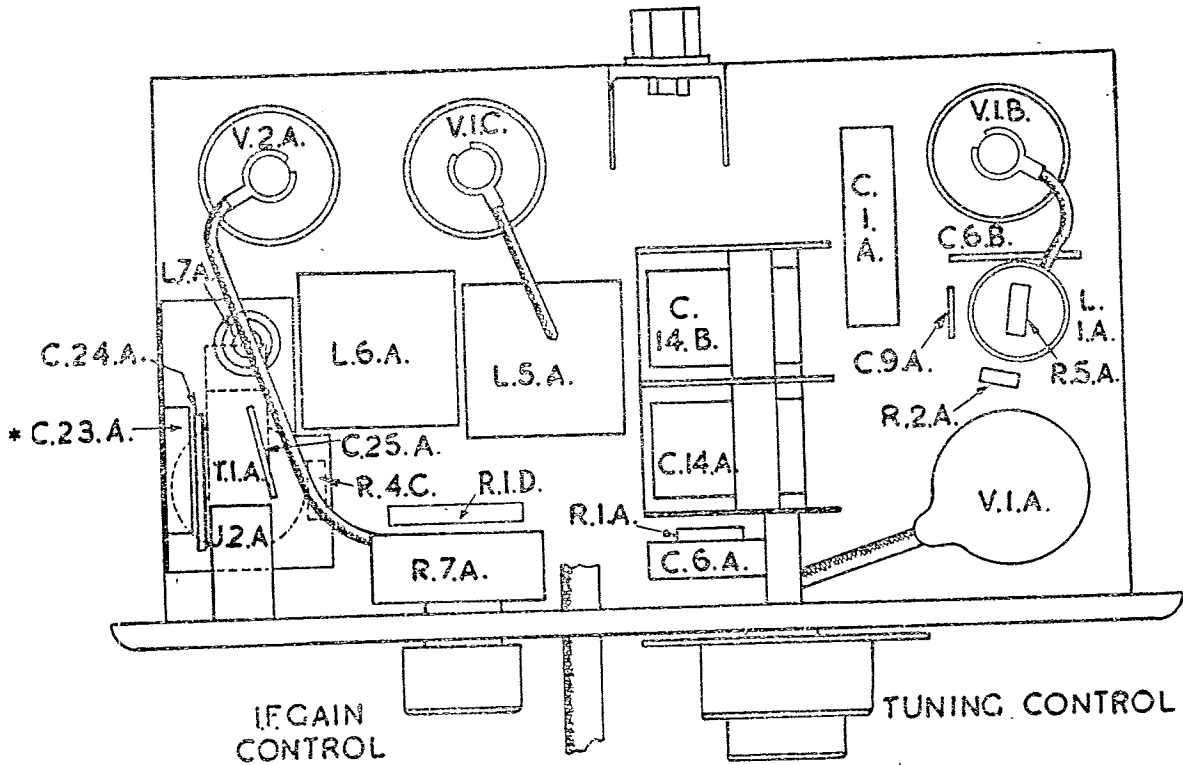

FIG. 3. TOP VIEW OF CHASSIS

* C.23A under chassis in certain sets.

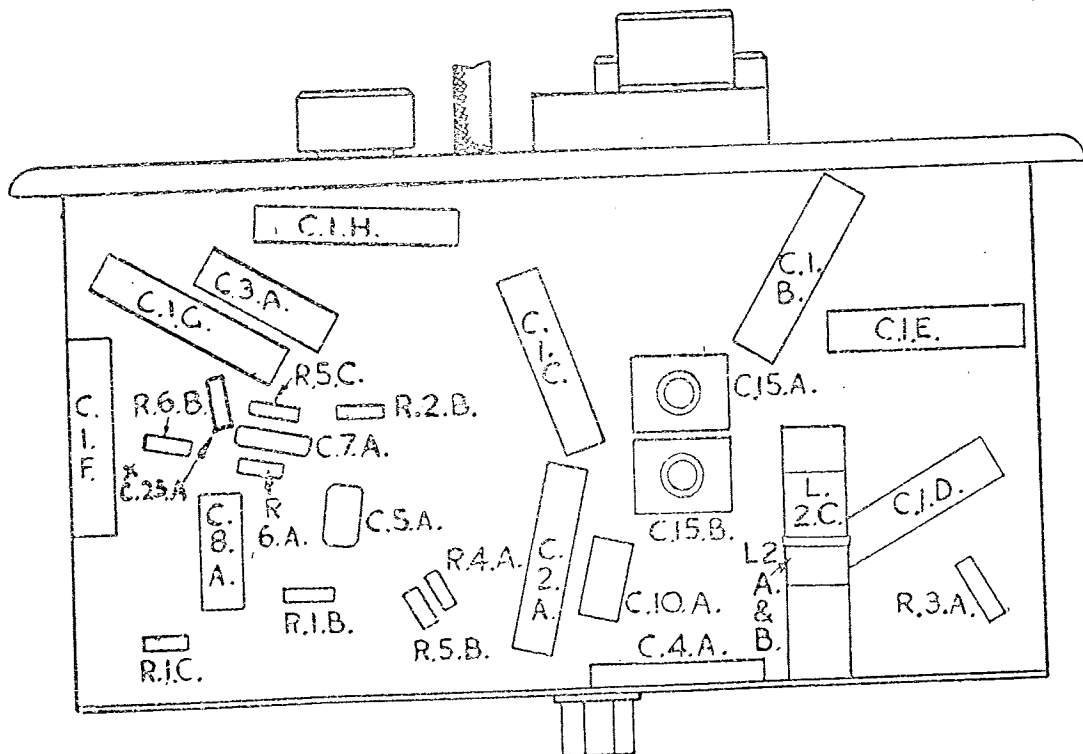

FIG. 4. UNDERSIDE VIEW OF CHASSIS

WIRELESS SET No. 18 MARK III SENDER

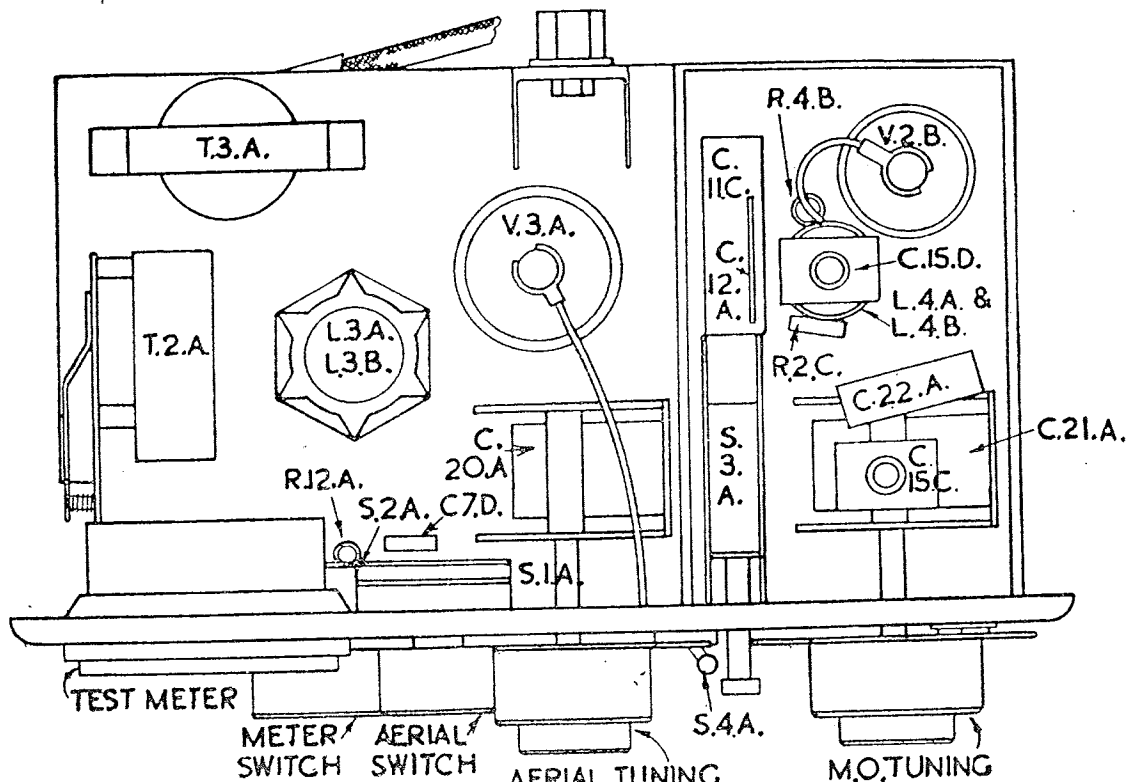

FIG. 5. TOP VIEW OF CHASSIS

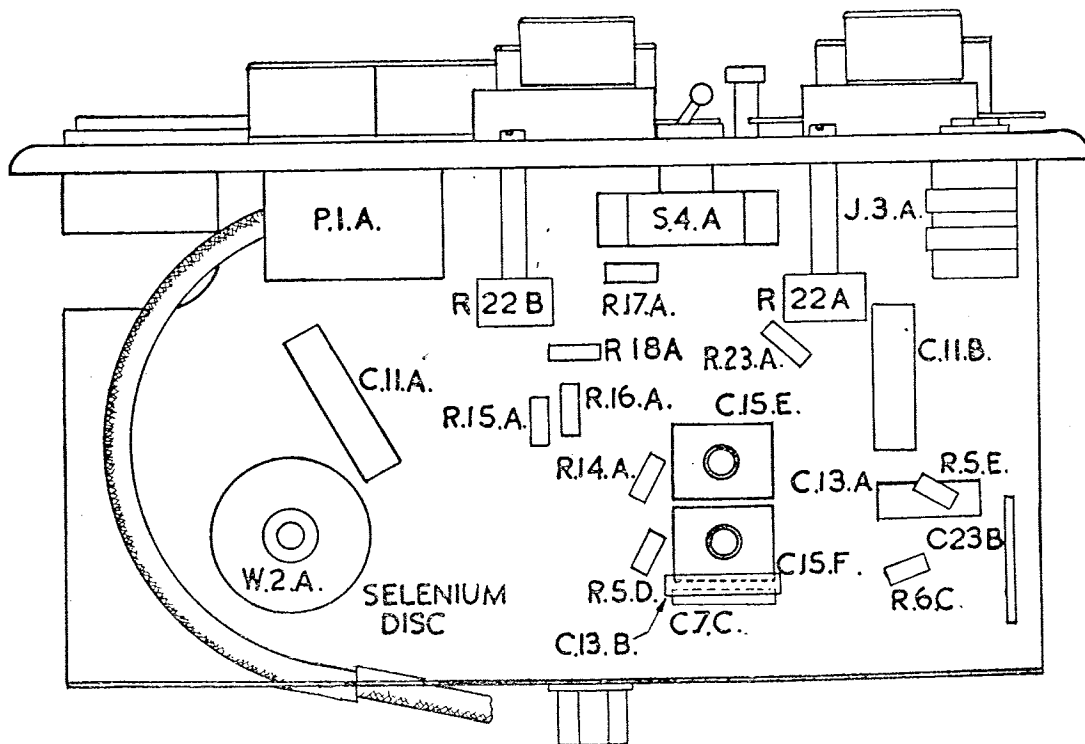

FIG. 6. UNDERSIDE VIEW OF CHASSIS

Refer to Prefatory Note p. 4 for differences between Wireless Sets No. 18 Mark I and Mark II.

WIRELESS SET NO. 18 MARK II

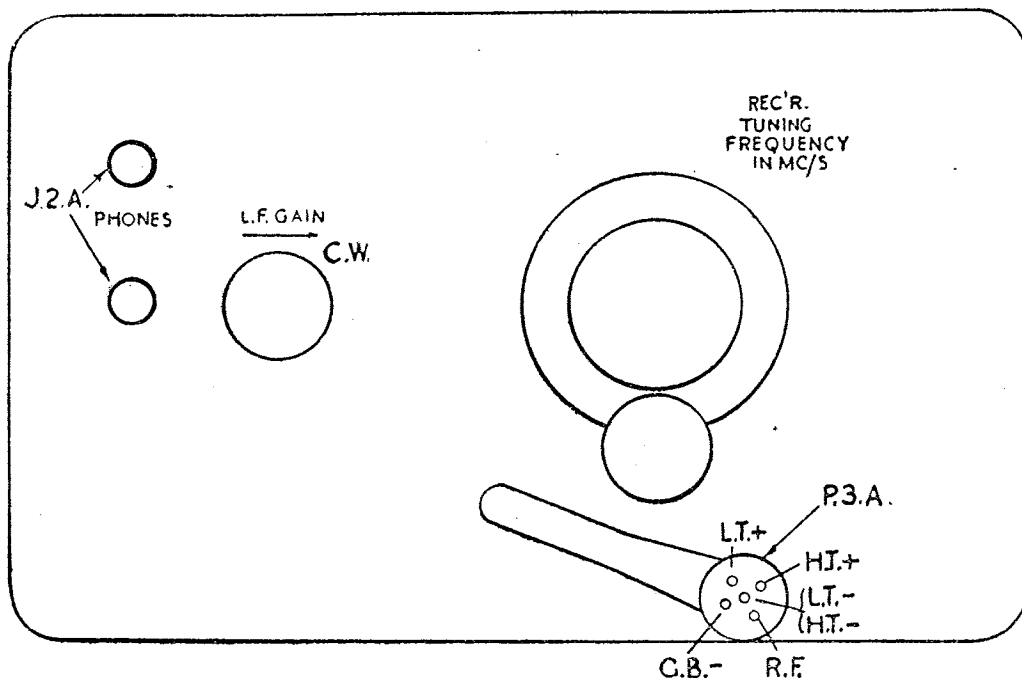
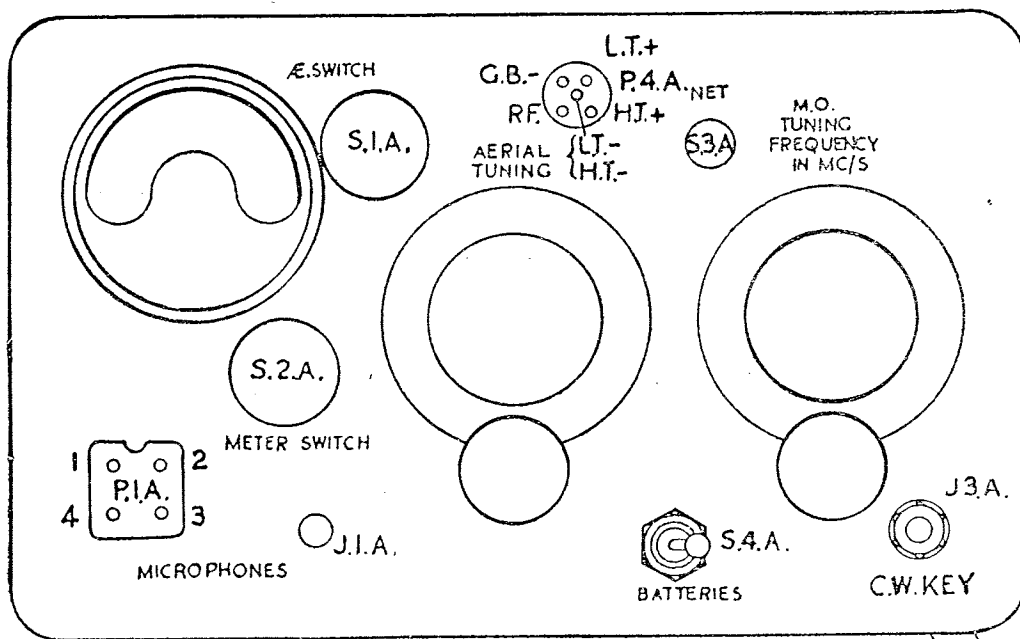

FIG. 7. FRONT VIEW OF RECEIVER PANEL



J.3.A. omitted on Wireless Set No 18 Mark I

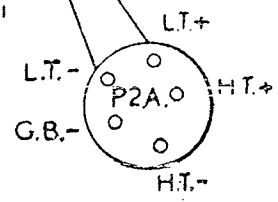

FIG. 8. FRONT VIEW OF SENDER PANEL

WIRELESS SET No. 18 MARK II RECEIVER

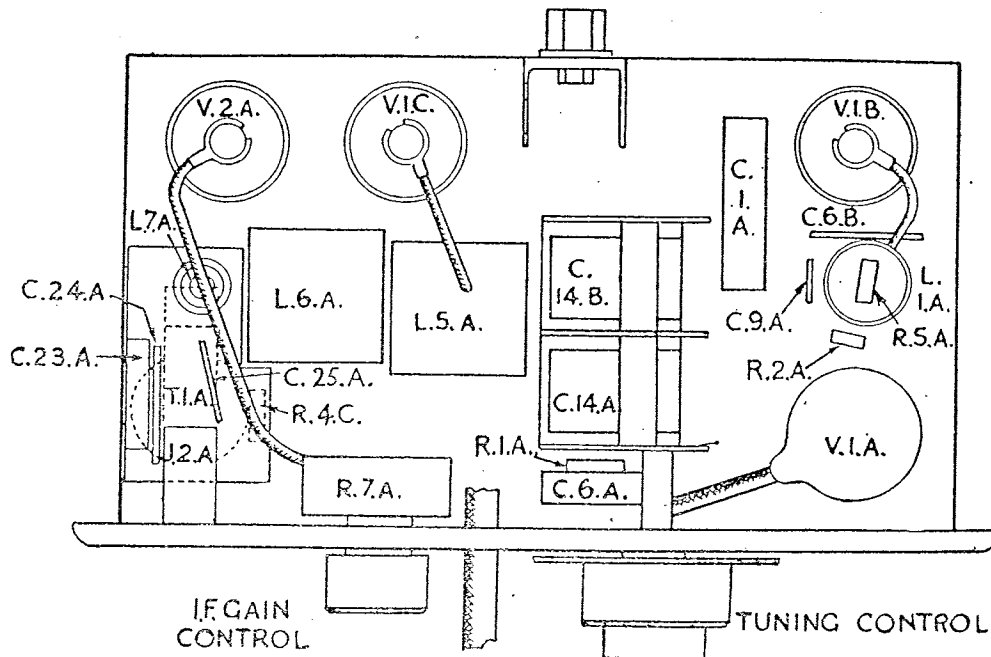

FIG. 9. TOP VIEW OF CHASSIS

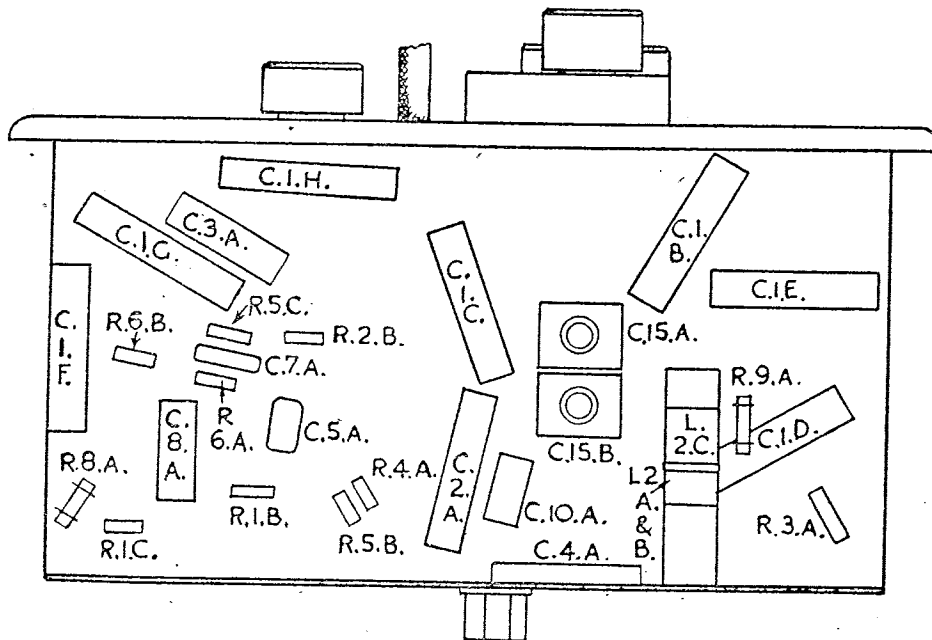

FIG. 10. UNDERSIDE VIEW OF CHASSIS

Refer to Prefactory Note p. 4 for differences
between Wireless Sets No. 18 Mark I and Mark II.

WIRELESS SET NO. 18 MARK II SENDER

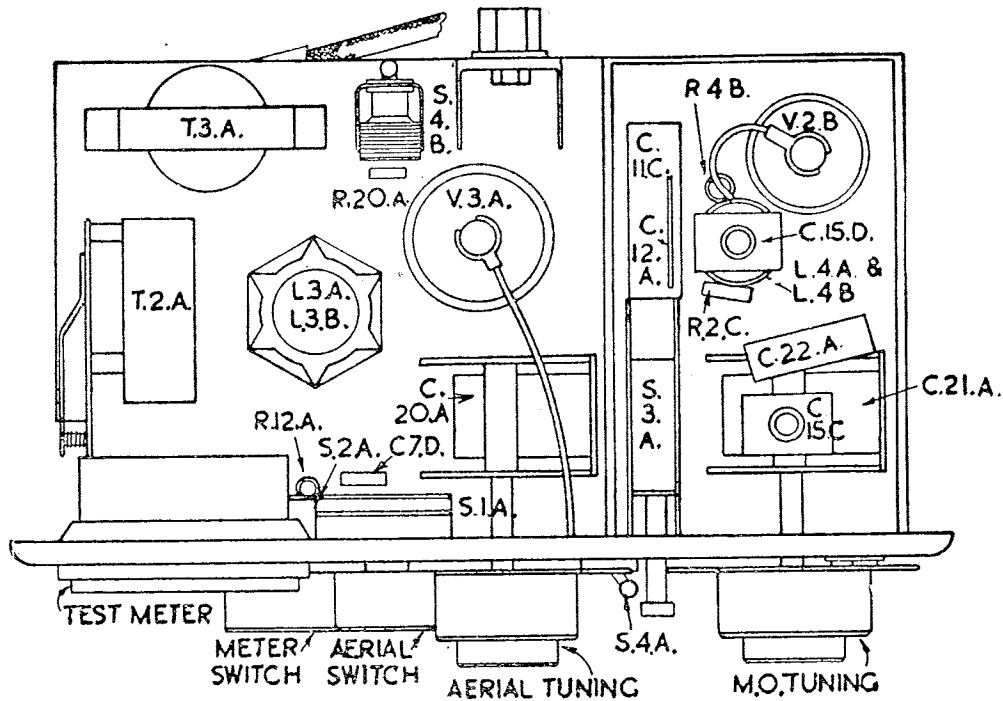

FIG. 11. TOP VIEW OF CHASSIS

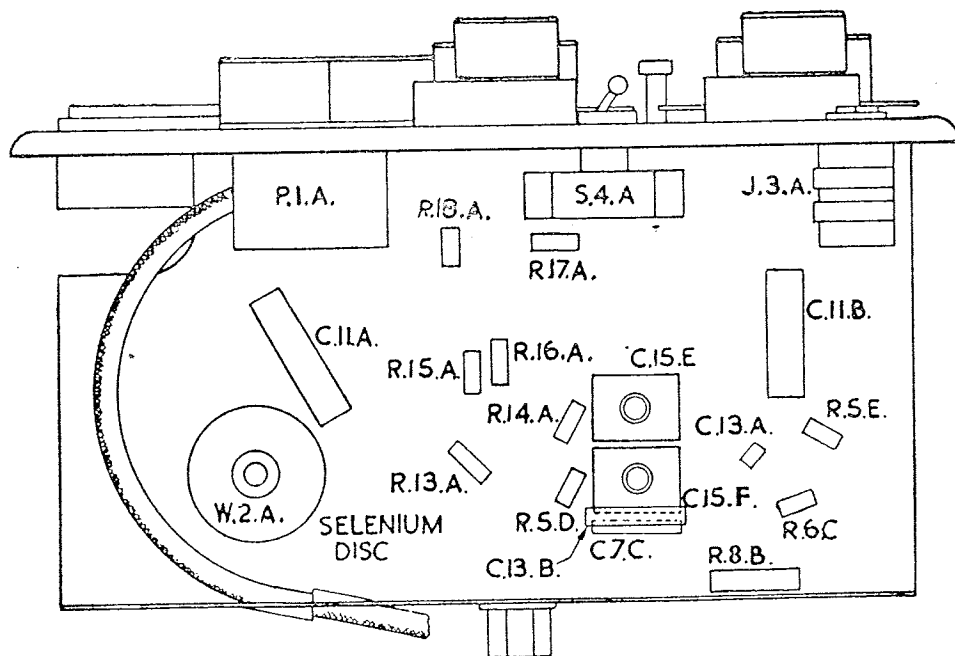
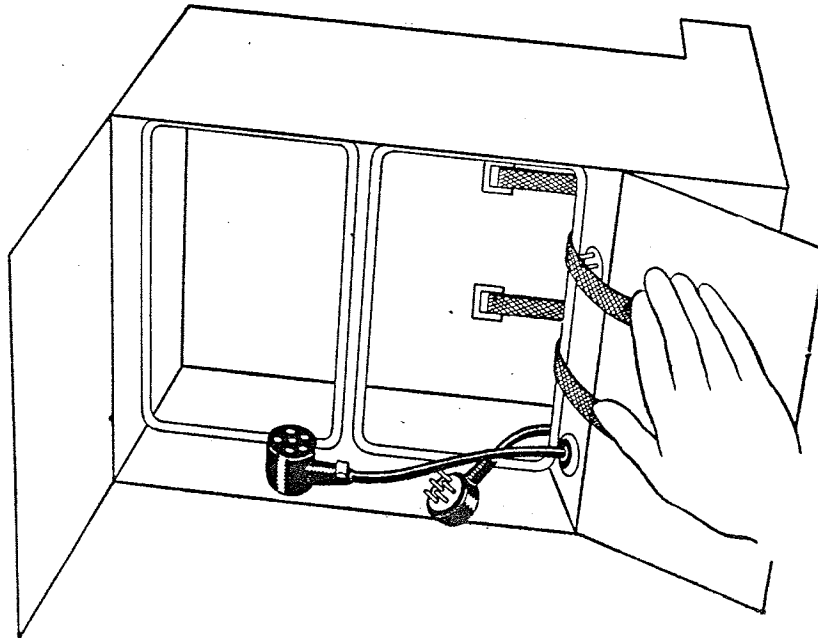
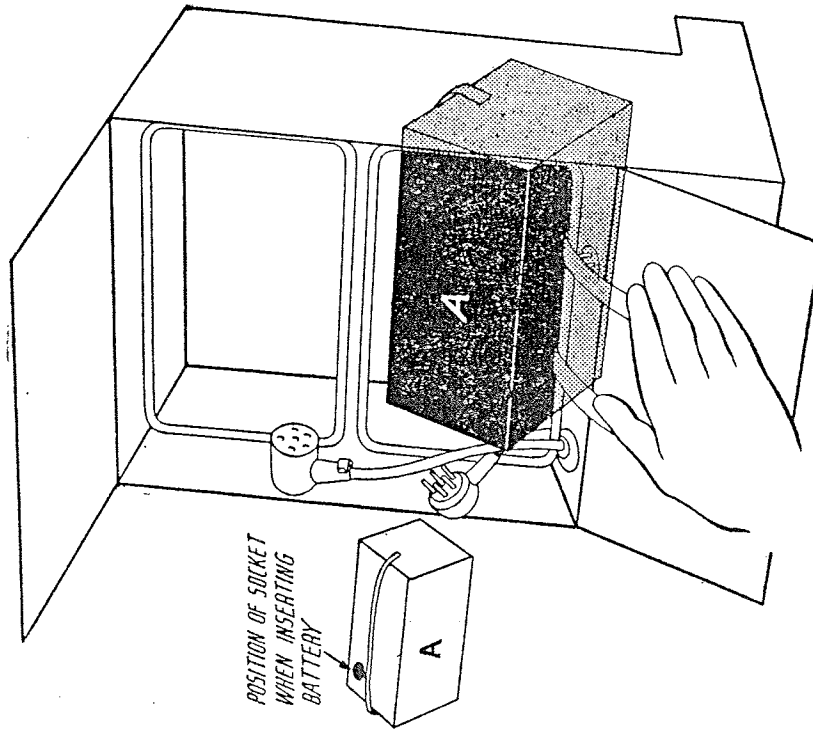

FIG. 12. UNDERSIDE VIEW OF CHASSIS

INSERTING AND REMOVING BATTERY



Tilt Case backwards so that Straps lie flat on back.
Hold ends of Straps as shown. See that Leads are
in position as above.



Insert Battery as shown and straighten up. To remove
reverse the action.

WIRELESS SETS, No. 18, COMPLETE STATIONS. NOS. I AND II.

[This schedule is not to be taken as authority for demanding stores.]

Item No. (1)	Part No. (2)	Designation (3)	No. 1 for R.T. only		No. 2 for R.T. and C.W.		Item No. (10)
			Minimum for work (4)	Essential spares (5)	Total (6)	Minimum for work (7)	
SECTION W.2.							
		Batteries, dry:—					
1	WB 1870	H.T./L.T., 162/3-volts	(a) 1	1	2	(a) 1	1
2	WB 1565	H.T., 60-volts, No. 1 (b)	2	2	4	2	2
3	WB 0027	Refil, 8-cell, No. 1, Mk. I (b)	3	3	6	3	3
4	WB 2230	Cells, dry, O (b)	2	2	4	2	4
SECTION Z.1.							
5	ZA 0227	Aerials, 25-ft., No. 1 (c)	1	—	1	1	5
6	ZA 0479	Antennae rod, B, sections	12	(d) 6	18	12	6
7	ZA 9817	Cases, 4-valve, No. 3	2	—	2	2	7
8	ZA 12580	Connectors, 5-point, No. 6, Mk. III (f)	1	—	1	1	8
9	ZA 4354	Key and plug assemblies, No. 8	—	—	—	(c) 1	9
10	ZA 5313	Microphones, hand, No. 4 (c) or 4A	1	—	1	1	10
11	ZA 5785	Receivers, headgear, C.L.R., double, Mk. III (c)	2	—	2	2	11
12	ZA 6292	Satchels, signals	1	—	1	1	12
13	ZA 7022	Valves, W.T., type:—	2	—	4	2	13
14	ZA 7023	A.R.8	3	(e) 2	6	3	14
15	ZA 5502	A.R.P.12	1	(e) 3	2	1	15
		A.T.P.4	—	(e) 1	—	—	—
16	ZA 3200	Wireless sets, No. 18:—	1	—	1	—	16
17	{ ZA 3230	Mk. I	—	—	—	—	—
18	{ ZA 3240	Mk. II or	—	—	—	—	—
	{ ZA 3207	Mk. III	1	—	1	1	18
		Working instructions	—	—	—	—	—
SECTION Z.2.							
19	ZB 0711	Boxes, primary bty., H.T. and L.T., No. 1	1	1	2	1	19

NOTES.

- (a) For use in set when used as man pack.
- (b) Normally carried in Boxes, primary bty., H.T. and L.T., No. 1 for use as external H.T. and L.T. battery when set is used as a fixed station.
- (c) Normally carried in Satchels, signals.
- (d) Normally carried at unit H.Q.
- (e) Normally carried in Cases, 4-valve, No. 3.
- (f) To connect set to external H.T. and L.T. batteries.

WIRELESS SET 18. Mark III

**SENDER AND RECEIVER
CIRCUIT DIAGRAMS**

FIGS. 13 and 14

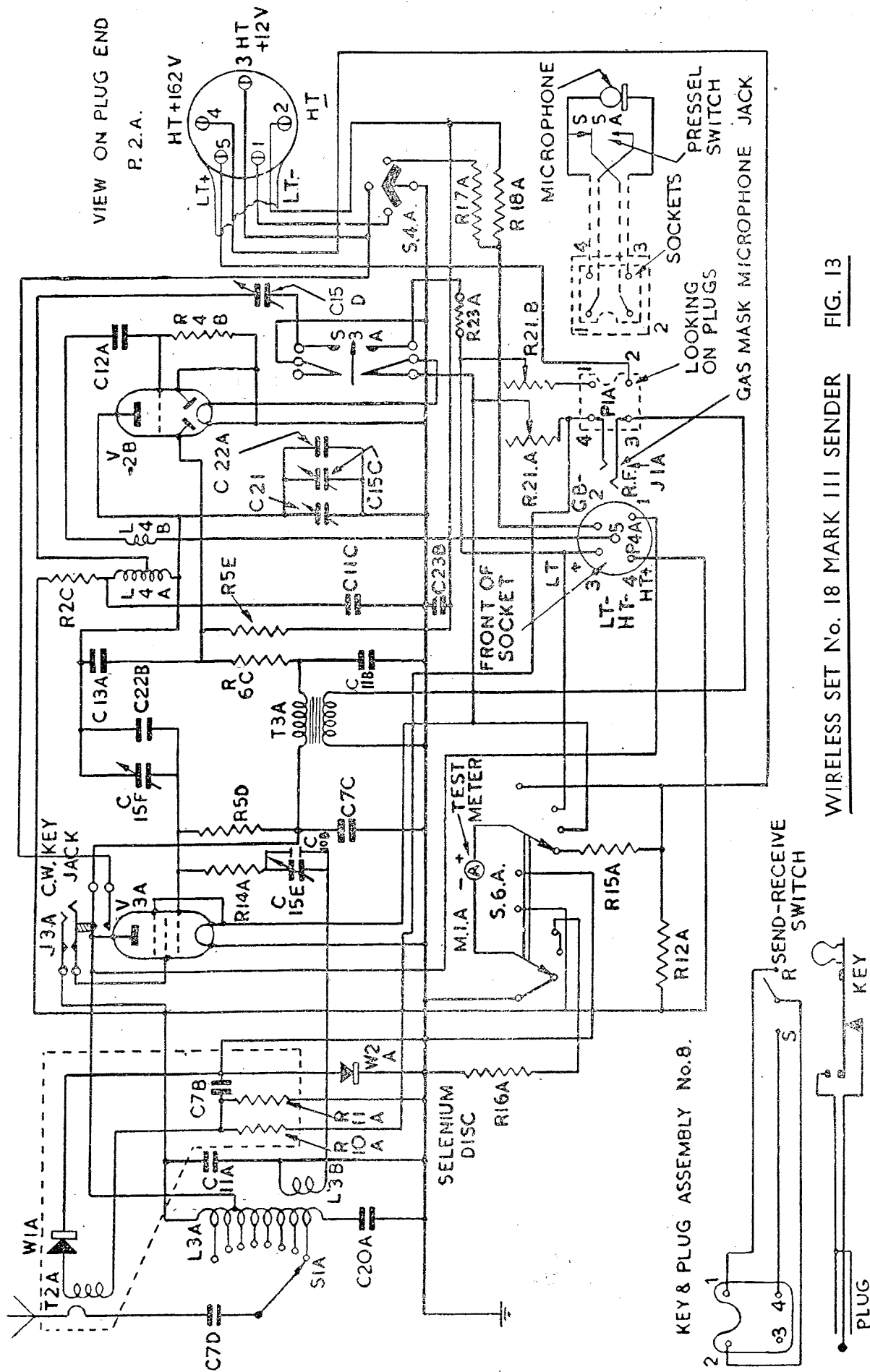

On Sets above serial No. 5720.

P.A. Anode and R.F. Lead to Rec. Is not common.

R.F. Lead is moved one Tap towards top end of Coil to Tap 4.

Anode connection remaining on Tap 5.

WIRELESS SET No. 18 MARK III SENDER FIG. 13

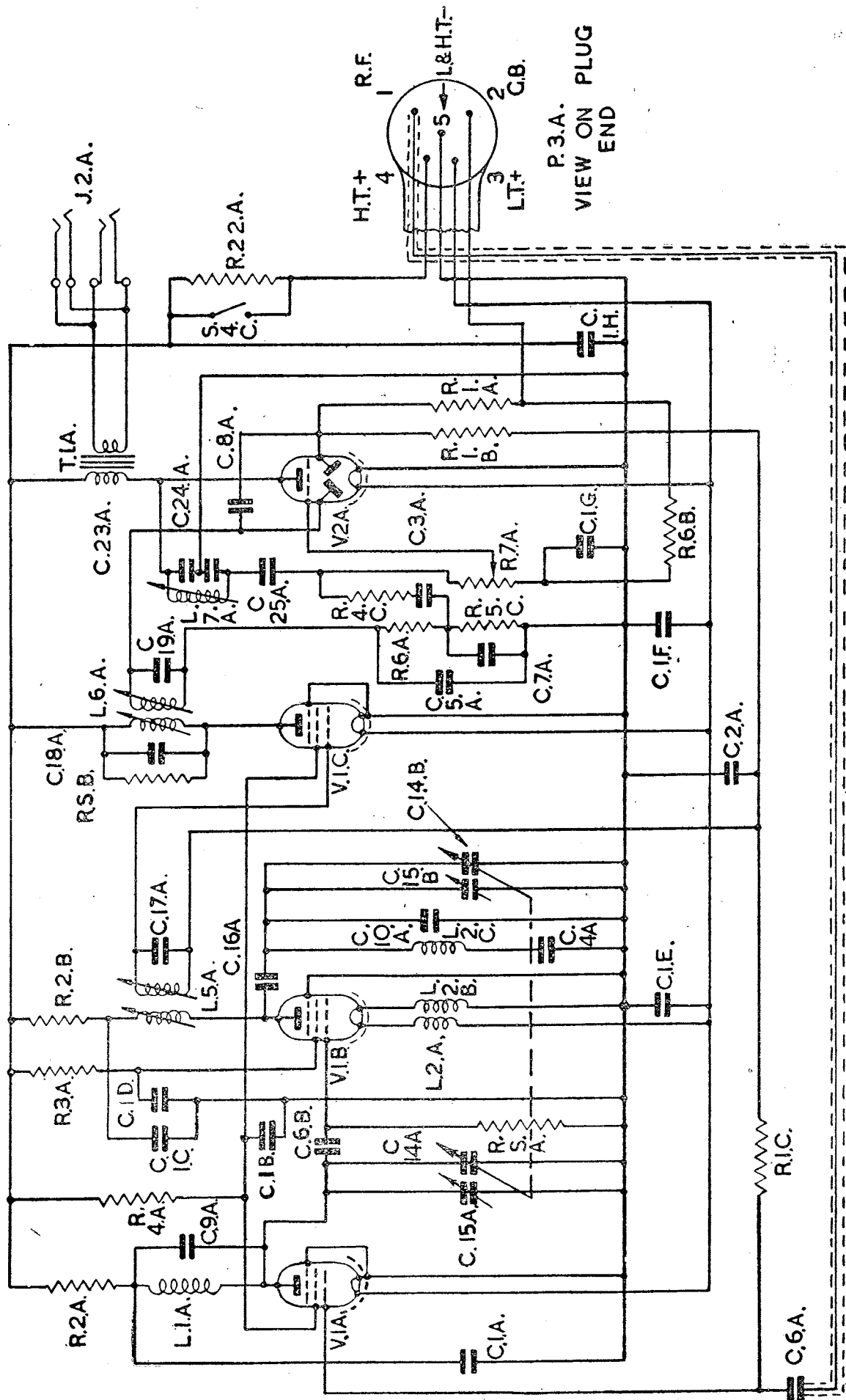

WIRELESS-SET No. 18 MARK III RECEIVER FIG. 14

On Sets serial Nos. 16,364 onwards.
R.I.D. is connected in parallel with R7A.

WIRELESS SET 18. Mark II

**SENDER AND RECEIVER
CIRCUIT DIAGRAMS**

FIGS. 15 and 16

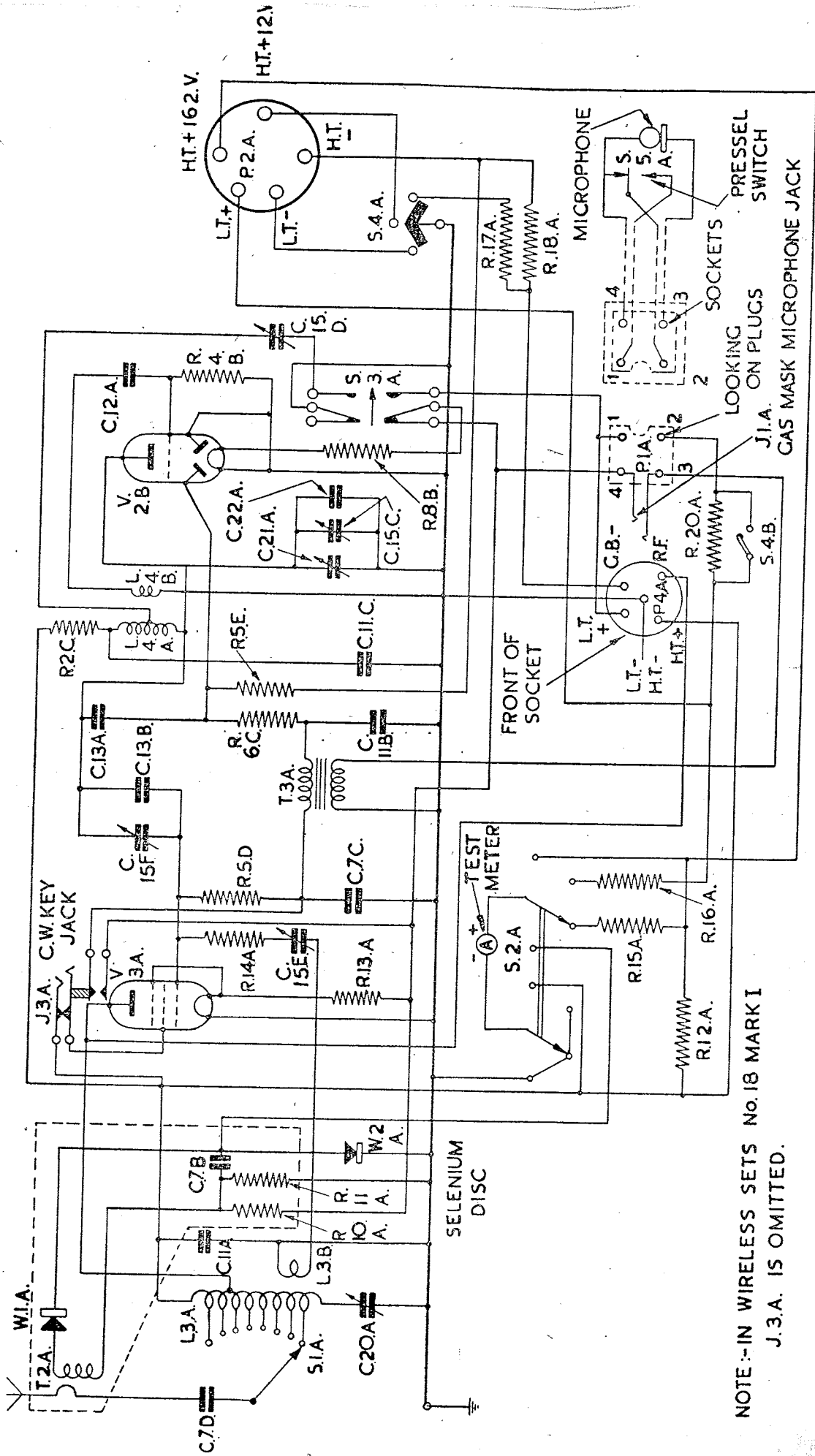

NOTE:- IN WIRELESS SETS No.18 MARK I
J.3.A. IS OMITTED.

WIRELESS SET No. 18 MARK II SENDER FIG. 15

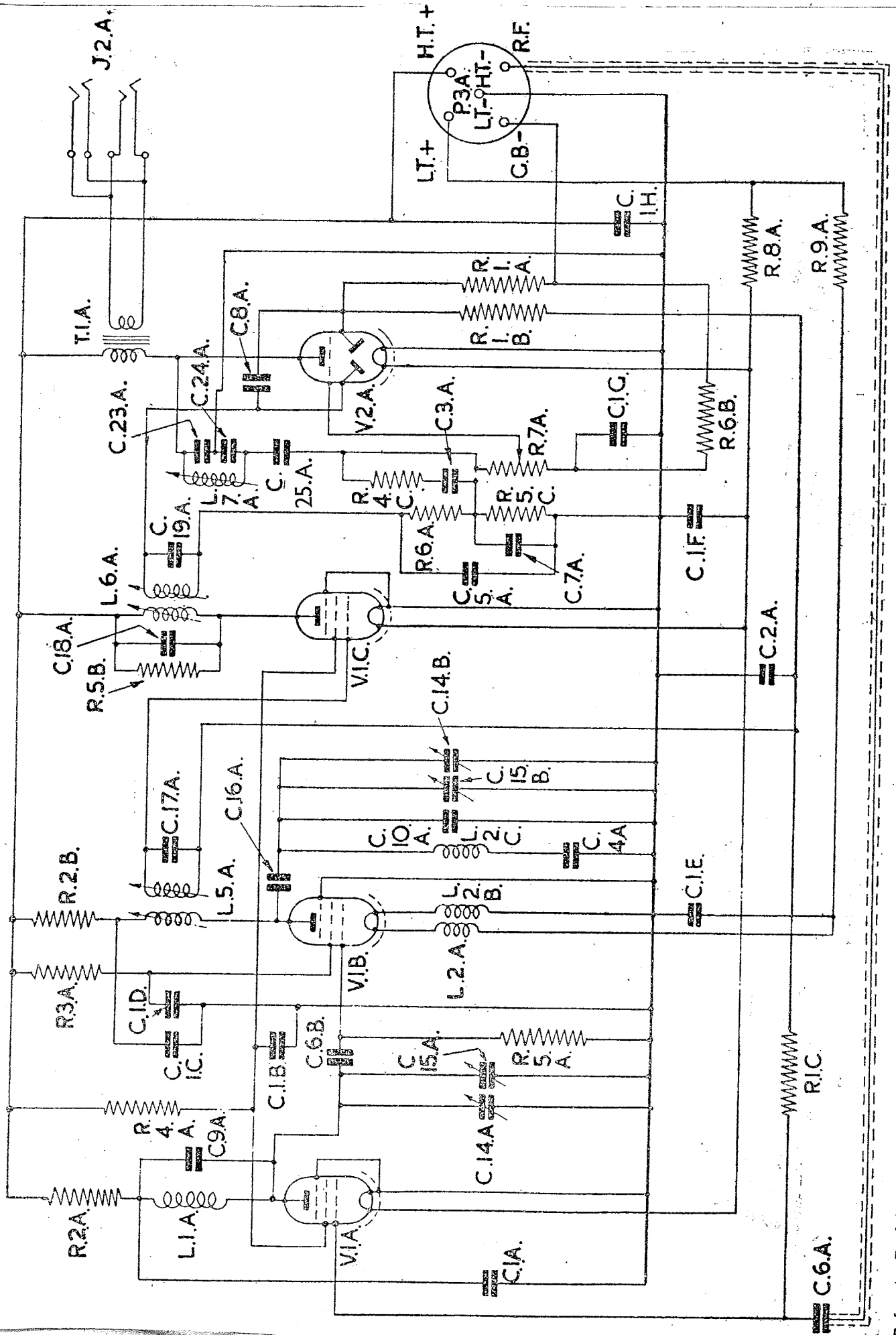

Refer to Prefatory Note p. 4 for differences between Wireless Sets No. 18 Mark I and Mark II.

WIRELESS SET No. 18 MARK II RECEIVER

FIG. 16

WIRELESS SET 18. Mark I

**RECEIVER
CIRCUIT DIAGRAM**

FIG. 17

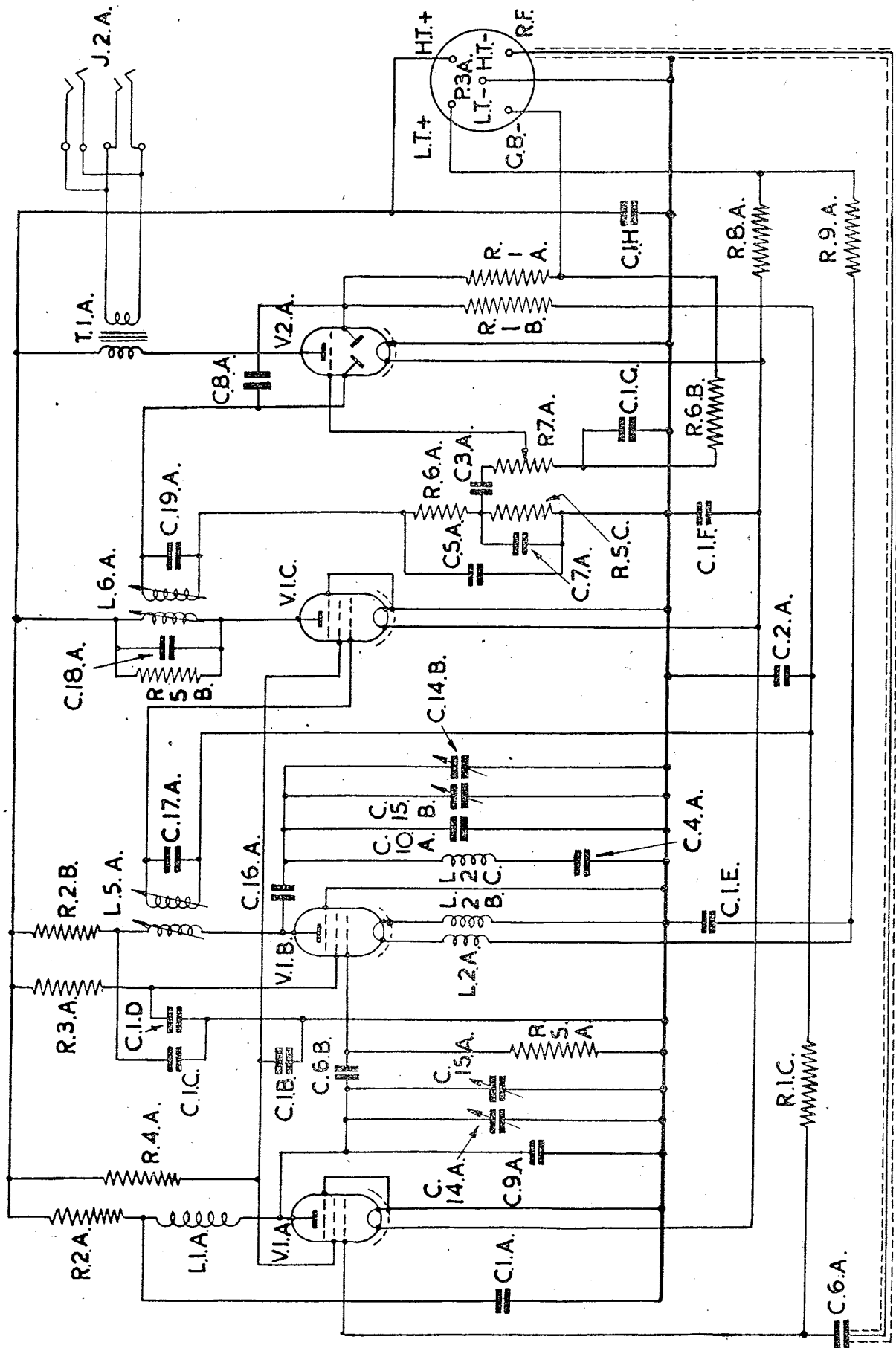

Refer to Prefatory Note p. 4 for differences of Wireless Sets No. 18 Mark I and Mark II.

WIRELESS SET No. 18 MARK I RECEIVER Fig. 17.